



The origin and evolution of human ampliconic gene families and ampliconic structure

Bejon Kumar Bhowmick, Yoko Satta and Naoyuki Takahata

Genome Res. 2007 17: 441-450 originally published online December 21, 2006

Access the most recent version at doi:[10.1101/gr.5734907](https://doi.org/10.1101/gr.5734907)

References This article cites 44 articles, 4 of which can be accessed free at:
<http://genome.cshlp.org/content/17/4/441.full.html#ref-list-1>

License

Email Alerting Service Receive free email alerts when new articles cite this article - sign up in the box at the top right corner of the article or [click here](#).



To subscribe to *Genome Research* go to:
<https://genome.cshlp.org/subscriptions>

Copyright © 2007, Cold Spring Harbor Laboratory Press

The origin and evolution of human ampliconic gene families and ampliconic structure

Bejon Kumar Bhowmick, Yoko Satta, and Naoyuki Takahata¹

Department of Biosystems Science, The Graduate University for Advance Studies (Sokendai), Kanagawa 240-0193, Japan

Out of the nine male-specific gene families in the human Y chromosome amplicons, we investigate the origin and evolution of seven families for which gametologous and orthologous sequences are available. Proto-X/Y gene pairs in the original mammalian sex chromosomes played major roles in origins and gave rise to five gene families: *XKRY*, *VCY*, *HSFY*, *RBMY*, and *TSPY*. The divergence times between gametologous X- and Y-linked copies in these families are well correlated with the former X-chromosomal locations. The *CDY* and *DAZ* families originated exceptionally by retroposition and transposition of autosomal copies, respectively, but *CDY* possesses an X-linked copy of enigmatic origin. We also investigate the evolutionary relatedness among Y-linked copies of a gene family in light of their ampliconic locations (palindromes, inverted repeats, and the *TSPY* array). Although any pair of copies located at the same arm positions within a palindrome is identical or nearly so by frequent gene conversion, copies located at different arm positions are distinctively different. Since these and other distinct copies in various gene families were amplified almost simultaneously in the stem lineage of Catarrhini, we take these simultaneous amplifications as evidence for the elaborate formation of Y ampliconic structure. Curiously, some copies in a gene family located at different palindromes exhibit high sequence similarity, and in most cases, such similarity greatly extends to repeat units that harbor these copies. It appears that such palindromic repeat units have evolved by and large en bloc, but they have undergone frequent exchanges between palindromes.

[Supplemental material is available online at www.genome.org.]

The male-specific region of the human Y chromosome (MSY), also previously called the nonrecombining portion of the Y chromosome (NRY), consists of three different classes of euchromatic sequences: X-transposed, X-degenerate, and ampliconic sequences (Skaletsky et al. 2003; Ross et al. 2005; see also Hughes et al. 2005 and Kuroki et al. 2006 for the available chimpanzee Y sequences of 9.5–12.7 Mb). The X-transposed sequences originated from an X-to-Y transposition 3–5 million years ago (Mya) and encode only two or three genes. The X-degenerate sequences are relics of ancient autosomes that have evolved toward the sex chromosomes (Ohno 1967; for reviews, see Graves 1995, 2002). The sequences encode 16 genes and 13 pseudogenes with their individual X-homologs. The ampliconic segments are composed of eight palindromes (P1–P8), three inverted repeats (IR1–IR3), and two arrays of no long open reading frames (NORF) and *TSPY* repeats. The segments encode nine gene families, seven of which are implicated in spermatogenesis or sperm production (Lahn and Page 1997; Skaletsky et al. 2003). These gene families are referred to as X Kell blood-related Y (*XKRY*), chromodomain Y (*CDY*), variable charge (*VCY*), deleted in azoospermia (*DAZ*), heat-shock transcription factor Y (*HSFY*), RNA-binding motif Y (*RBMY*), testis-specific Y (*TSPY*), basic protein Y2 (*BPY2*), and PTP-BL related Y (*PRY*) (see Table 1 for their brief accounts of functions and references).

There are quite a few reports on origins for *CDY*, *DAZ*, *HSFY*, *RBMY*, and *TSPY*. Any model for the origin of these genes invokes retroposition of autosomal gene transcripts, duplicated transposition of autosomal loci, or proto-X/Y pairs of genes in the original mammalian sex chromosomes. Lahn and Page (1999a) sug-

gested that autosomal *CDYL* gave rise to *CDY* by retroposition in the stem lineage of simian primates and that *CDYL* and *CDY* have since undergone functional partitioning of housekeeping and testis-specific functions. Later, by examining *CDYL* and its early autosomal duplicate *CDYL2*, Dorus et al. (2003) pushed the origin of *CDY* back before the Eutherian radiation. Regarding other gene families, it was hypothesized that retroposition resulted in *HSFY* (Tessari et al. 2004) and transposition resulted in *DAZ* (Saxena et al. 1996; Lahn and Page 1999a), *RBMY* (Chai et al. 1998; Elliott et al. 2000), and *TSPY* (Lahn and Page 1999a). However, another group proposed the proto-X/Y pair origin of *RBMY* (Delbridge et al. 1998, 1999; Lingenfelter et al. 2001) and *TSPY* (Delbridge et al. 2004).

The ampliconic gene families are expressed predominantly or exclusively in testes (Skaletsky et al. 2003), and six of them are found only in primates. It is therefore tempting to ask where they came from and how their origin affected the function on the primate Y chromosome. It is also interesting to examine the evolutionary relationships between ampliconic genes and surrounding ampliconic regions per se (Kuroda-Kawaguchi et al. 2001; Rozen et al. 2003; Skaletsky et al. 2003). The purpose of this paper is twofold. First, we study the origin of ampliconic genes based on currently available genome sequence data. We show that *XKRY*, *VCY*, and *HSFY* originated from proto-X/Y gene pairs in addition to *RBMY* and *TSPY*. We examine whether the divergence times of these five genes from the X-linked homologs agree with the stepwise differentiation pattern of the Eutherian sex chromosomes, as the evolutionary stratum hypothesis can predict (Lahn and Page 1999b). Second, as a gene family usually scatters multiple copies within and between different ampliconic regions, we study the evolutionary relationships among copies in light of their ampliconic locations. We pay special attention to low sequence similarity among copies that are located in different arm

¹Corresponding author.

E-mail takahata@soken.ac.jp; fax 81-46-858-1542.

Article published online before print. Article and publication date are at <http://www.genome.org/cgi/doi/10.1101/gr.5734907>.

Table 1. Brief functional accounts of the nine ampliconic genes and references

Genes	Gene products and effects	References
<i>XKRY</i>	XK-related putative membrane transport protein	Lahn and Page 1997
<i>CDY</i>	Chromodomain, which likely plays a role in chromatin binding, and catalytic domain predicted to participate in acylation reactions	Lahn and Page 1997, 1999a; Dorus et al. 2003
<i>VCY</i>	Nuclear protein involved in the regulation of ribosome assembly during spermatogenesis and responsible for mental impairment associated with X-linked ichthyosis	Lahn and Page 2000; Zou et al. 2003
<i>DAZ</i>	Candidate fertility factor; deletion of the region is a common cause of spermatogenic failure	Saxena et al. 1996, 2000
<i>HSFY</i>	Heat-shock transcription factor with an HSF-type DNA-binding domain; involved in azoospermia or oligospermia	Tessari et al. 2004
<i>RBMY</i>	Germ-cell-specific nuclear protein implicated in spermatogenesis	Delbridge et al. 1997; Chai et al. 1998
<i>TSPY</i>	Candidate for the gonadoblastoma promoting factor and involvement in early spermatogenesis	Schnieders et al. 1996
<i>BPY2</i>	Protein that interacts with ubiquitin protein ligase E3A and may be involved in male germ-cell development and male infertility	Lahn and Page 1997
<i>PRY2</i>	Protein that has a low degree of similarity to protein tyrosine phosphatase, non-receptor type 13	Stouffs et al. 2001

positions within a palindrome as well as high sequence similarity among copies that are located in different palindromes. We extend this analysis to the entire region of the 2.9-Mb palindrome P1 and demonstrate massive sequence transfers with autosomal repeat units and other Y-chromosomal palindromes.

Results

Gametologs, orthologs, and amplicons

In searching for origins of the ampliconic genes, it is essential to include X-linked and autosomal homologs or more precisely gametologs, if present in the genome, as well as their orthologs in critical phylogenetic positions. Despite the fact, by definition, that the ampliconic genes are located outside the X-degenerate segments, it turns out that each of six gene families has an X-linked gametolog in evolutionary strata 1, 2, or 4. Lahn and Page (1999b) found that during mammalian evolution, the X/Y chromosomal differentiation took place in a stepwise fashion; one stratum at a time. Stratum 1, covering almost the entire long arm of the human X chromosome, is the oldest among four or five strata, and the formation predated the divergence between Monotherians and Metatherians/Eutherians, 210 Mya (Lahn and Page 1999b; Skaletsky et al. 2003; Ross et al. 2005; Waters et al. 2005). Stratum 2 occupies a rather small proximal region of the X short arm and was formed before Metatherians and Eutherians

diverged, 180 Mya. On the other hand, stratum 4 was formed independently within individual Eutherian orders (Iwase et al. 2003) and in primates; it was deposited in the stem lineage of simian primates, >50 Mya. Stratum 1 harbors gametologous *XKRX* of *XKRY*, *HSFX* of *HSFY*, and *RBMX* of *RBMY*; stratum 2 harbors *TSPX* of *TSPY*; and stratum 4 harbors *CDX* of *CDY* and *VCX* of *VCY*. In addition to these X-linked copies, each of *XKRY*, *CDY*, *DAZ*, *HSFY*, *RBMY*, and *TSPY* has at least one autosomal copy in the human genome. On the other hand, the availability of orthologs varies among gene families, sometimes reflecting true presence or absence in the genome or in the databases.

Table 2 lists the nine gene families with their gametologs, proposed origin hypotheses, and species for which we found orthologs of human Y ampliconic genes. The number of exons per gene is included to infer molecular mechanisms involved in the origins, although intronless genes such as *XKRY1* and *XKRY2* did not always result from retroposition, and conversely, intron-containing genes such as *CDY1* originated via retroposition and subsequent acquisition of introns (Lahn and Page 1999a). For the *BPY2* family (Lahn and Page 1997), there exist three nearly identical genes—*BPY2B* and *BPY2C* in palindrome P1 and *BPY2* in a proximal region adjacent to palindrome P2. For the *PRY* family (Stouffs et al. 2001), there exist paired *PRY1* and *PRY2* and their shorter versions of paired *PRY3* and *PRY4* in palindrome P3 and P4, respectively. Unfortunately, neither *BPY2* nor *PRY* possesses any detectable X-linked or autosomal copy, and little is known

Table 2. Ampliconic genes in the human Y chromosome, their homologs, and proposed hypotheses for origins

Functional ampliconic genes (E) ^a	X-linked gametolog (E) ^a	Autosomal gametolog (E) ^a	Species available for Y orthologs	Proposed origin hypotheses ^b and references
<i>XKRY1/2</i> (1E)	<i>XKRX</i> (3E)	<i>XKRYL</i> (4E)	Chimpanzee	Unknown
<i>CDY1</i> (2E), <i>CDY2</i> (1E)	<i>CDX</i> (3E)	<i>CDYL</i> (9E), <i>CDYL2</i> (7E)	Chimpanzee, OWMs	RP of <i>CDYL</i> (Lahn and Page 1999a)
<i>VCY1/2</i> (2E)	<i>VCX</i> , 2, 3A/B (2E)	None	Chimpanzee	Unknown
<i>DAZ1-4</i> (>11E)	None	<i>DAZL</i> (10E)	Chimpanzee, OWMs	TP of <i>DAZL</i> (Saxena et al. 1996)
<i>HSFY1/2</i> (2E)	<i>HSFX1/2</i> (3E)	<i>HSFY</i> (1E)	Chimpanzee, mouse, rat	RP of <i>HSFYL</i> (Tessari et al. 2004)
<i>RBMY1/2</i> (12E)	<i>RBMX</i> (9E), <i>RBMX2</i> (1E)	<i>RBMXL1</i> , 4, 6, 9 (1E)	Mouse, marsupials	TP of <i>RBMXL</i> (Chai et al. 1998), XY (Delbridge et al. 1999)
<i>TSPY1/2</i> (6E)	<i>TSPX</i> (7E)	<i>TSPYL1</i> , 3-6 (1E)	Chimpanzee, rat	TP of <i>TSPYL</i> (Lahn and Page 1999a), XY (Delbridge et al. 2004)
<i>PRY1/2</i> (5E), <i>PRY3/4</i> (3E)	None	None	Chimpanzee	Unknown
<i>BPY2</i> , B, C (9E)	None	None	None	Unknown

^a(E) Number of exons.

^b(RP) Retroposition; (TP) transposition; (XY) proto-X/Y gene pair.

about their orthologs. Under these circumstances of available sequence data, we exclude these two gene families from our phylogenetic analysis.

Supplemental Table 1 gives the accession numbers of the sequences of the seven ampliconic gene families and their X-linked and autosomal gametologs, as well as their orthologs when they are used in the phylogenetic analysis. Figure 1 represents ampliconic structure in the human Y chromosome and the chromosomal locations of Y copies we use. Among the eight palindromes, P1 of 1.45-Mb arm length is the largest and harbors two pairs of *XKRY*, four pairs of *CDY*, and one pair of each of *RBMY* and *DAZ* in our data set. Similarly, the second largest P5 spans nearly 0.50 Mb in its arm length and harbors one pair of *XKRY* and three pairs of *CDY*. Inverted repeat 2 (IR2) encodes two pairs of *RBMY*, and the *TSPY* array encodes 12 copies.

Proto-X/Y origins

XKRY

We found eight *XKRY* copies, one X-linked *XKRX*, and one autosomal *XKRYL* in the human genome. The coding sequence of human *XKRX* shows a high degree of evolutionary conservation with some Eutherian orthologs being >80% similar at the DNA sequence level. The presence of *XKRX* raises the possibility that *XKRY* has an origin similar to that of genes in the X-degenerate class. Phylogenetic comparison of *XKRY*-related gametologous and orthologous sequences identifies three distinct clusters: Eutherian *XKRX*; a pair of human and chimpanzee *XKRYL*; and 10 intermingled human and chimpanzee *XKRY* genes and pseudogenes (Fig. 2A). It is clear that two monophyletic clusters of *XKRX* and *XKRY/XKRYL* differentiated from each other well before the

Eutherian radiation and that later in simian primate evolution, *XKRY* and *XKRYL* began to evolve independently. The estimated extent of synonymous divergences (k_{XY}) between *XKRX* and *XKRY* is as large as 1.128 ± 0.236 , in agreement with the values in stratum 1 reported by Lahn and Page (1999b) and Skaletsky et al. (2003). The putative coding region of *XKRY* starts in exon 4 of *XKRX/XKRYL*. The translated and 3'-untranslated regions of *XKRY* have sequence similarity to the corresponding regions of *XKRX/XKRYL*. Moreover, the 5'-flanking region of *XKRY* shows sequence similarity to exon 1 and part of intron 3 of *XKRYL*. All of these features support the notion that *XKRY* did not result from retroposition, but from a proto-X/Y gene pair.

A duplicated copy of *XKRY* was transposed to create autosomal *XKRYL*. Based on the extent of synonymous divergences ($k_{YL} = 0.120 \pm 0.045$) between *XKRY* and *XKRYL*, we date the transposition event as 41 ± 15 Mya (see Methods). At this point, proto-*XKRY* still had an exon and intron structure similar to *XKRX* (Table 2). Yet, there is one base-pair deletion specific to a pair of nearly identical *XKRY1/2* copies, and this deletion creates a new initiation codon and new coding frame. It therefore appears that *XKRY1/2* are functional, but the remaining six copies are nonfunctional and designated as *XKRYP1-6* with suffix P (Figs. 1 and 2A).

VCY

We found two *VCY* and four X-linked *VCX* copies in the human genome. The presence of *VCX* in stratum 4 suggests that *VCX* and *VCY* evolved from a proto-X/Y gene pair in the X added region (XAR) (Graves 1995, 2002). The nucleotide differences between X-linked sequences in stratum 4 and the gametologous Y sequences are ~10% per site on average (Lahn and Page 1999b;

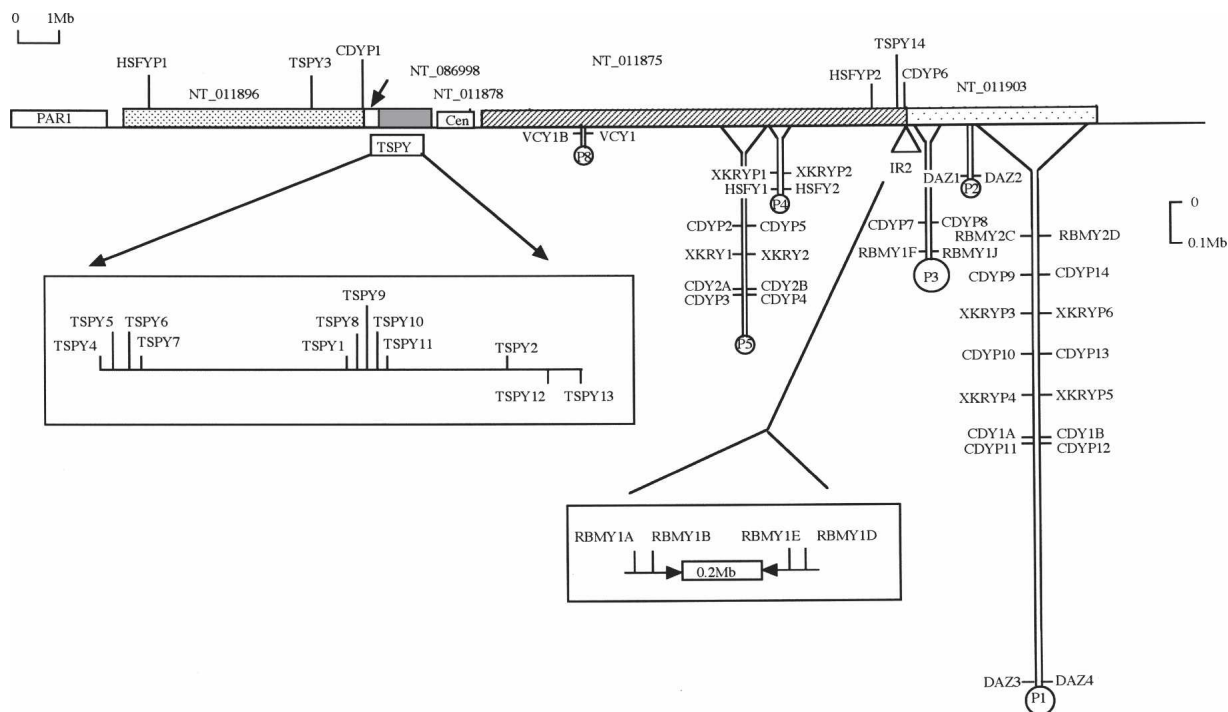

Figure 1. Chromosomal locations of human ampliconic genes and pseudogenes based on contigs, as well as MapViewer display of BLASTN results (see also Supplemental Table 1). The abscissa represents the ~24-Mb euchromatic region with the Yp pseudoautosomal region at the left-most end. Palindromes are shown as hairpin-like structures; expanded views of the *TSPY* array and IR2 are shown in boxes.

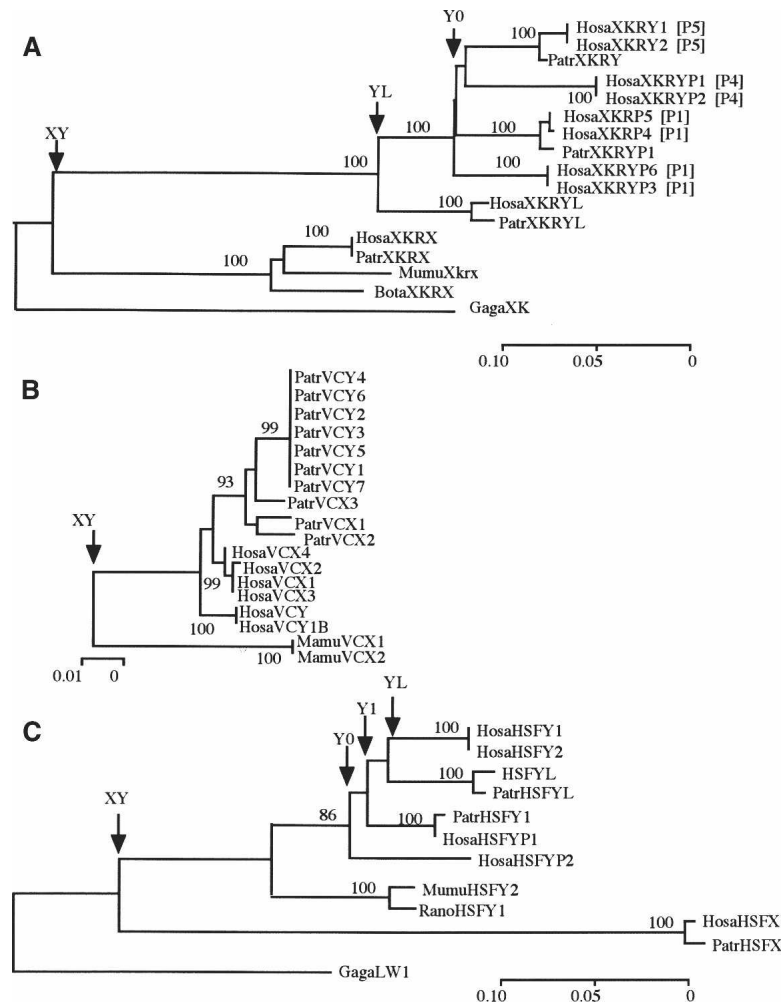

Figure 2. NJ trees of (A) *XKRY*, (B) *VCY*, and (C) *HSFY*. Whenever chicken homologs are available, they are used for rooting the trees. In A, palindromic locations of human *XKRY* copies are indicated by bracketed P1, P4, and P5. The numbers next to nodes show the bootstrap values in 1000 replications. Node XY, YL, and Y0 stand for X/Y differentiation, retroposition from Y to autosome or vice versa, and coalescence of all human Y copies, respectively. The accession numbers of the DNA sequences and the sequence alignments are given in Supplemental Table 1 and Supplemental Figure 1, respectively. The gene nomenclature follows a four-letter prefix system to indicate genus and species names: (*Hosa*) *Homo sapiens*; (*Patr*) *Pan troglodytes*; (*Mamu*) *Macaca mulatta*; (*Mafa*) *Macaca fascicularis*; (*Paha*) *Papio hamadryas*; (*Ceap*) *Cebus apella*; (*Saoe*) *Saguinus oedipus*; (*Sasc*) *Saimiri sciurea*; (*Cafa*) *Canis familiaris*; (*Susc*) *Sus scrofa*; (*Bota*) *Bos taurus*; (*Mumu*) *Mus musculus*; (*Rano*) *Rattus norvegicus*; (*Maeu*) *Macropus eugenii*; (*Smma*) *Sminthopsis macroura*; (*Gaga*) *Gallus gallus*.

Iwase et al. 2003). However, the observed synonymous and non-synonymous differences between human *VCX* and *VCY* are merely 2.2% and 3.3% per site, respectively. These values are too small to be consistent with the expected extent of synonymous divergences for a proto-X/Y gene pair in stratum 4 (but see Skalesky et al. 2003).

Both *VCX* and *VCY* can also be found in chimpanzees, but other sequence data are available only for rhesus monkeys; two *VCX* genes and one fragmental copy. Despite this limited availability of *VCY*-related sequences, they show some interesting evolutionary features. First, chimpanzee *VCX* and *VCY* are more closely related to each other than they are to their orthologous genes in humans (Fig. 2B), suggesting that chimpanzee *VCY* was recently converted by the gametolog and then amplified to generate seven nearly identical copies. Second, the average k_{XY} value between rhesus monkey *VCX* and hominoid *VCX* and *VCY* is

0.189 ± 0.048 . This extent is too large to be expected from the silent substitution rate (Ebersberger et al. 2002) and the 30-Myr divergence between hominoids and Old World monkeys (OWMs) (Martin 1993; Takahata 2001; but see also Kumar and Hedges 1998). However, the observed k_{XY} value is very similar to that for *STS* adjacent to *VCX* in stratum 4 (Skalesky et al. 2003). It is therefore likely that the differentiation between rhesus monkey *VCX* and the ancestral lineage of hominoid *VCX* and *VCY* predated the species divergence, owing to the earlier differentiation between gametologous *VCX* and *VCY*. Consistent with this proto-X/Y origin model, Lahn and Page (2000) and Fukami et al. (2000) detected both *VCX* and *VCY* in simian primates by low-stringency hybridization.

HSFY

In addition to two functional *HSFY* and several pseudogenes, we found one X-linked *HSFX* and one autosomal (*HSFYL*) copy in the human genome. Here we used only two pseudogenes in our analysis because inclusion of all of the pseudogenes would have prevented us from comparing *HSFY* with *HSEFX* and *HFSYL*, owing to mutually exclusive gaps among these genes. Figure 2C shows that a proto-X/Y gene pair of *HSFX* and *HSFY* existed in the original mammalian sex chromosomes and differentiated from each other well before the Eutherian radiation. This is consistent with the location of *HSFX* in stratum 1 and the k_{XY} value of 0.992 ± 0.294 between *HSFX* and *HSFY*.

Tessari et al. (2004) proposed that *HSFY* arose via retroposition of *HSFYL*, whereas we demonstrate that the reverse happened. That is, intronless *HSFYL* arose via retroposition of *HSFY* with two exons. Conversely, if *HSFY* arose via retroposition of *HSFYL*, it becomes difficult to account for the presence of *HSFY* in mice and rats. Actually, the k_{YL} value of 0.058 ± 0.039 between *HSFY1/2* and intronless *HSFYL* indicates that the retroposition of *HSFY* occurred as recently as 20 ± 13 Mya. Prior to this retroposition, *HSFY* began to amplify, producing at least three distinct pseudogene lineages in humans. In the linearized tree (Takezaki et al. 1995), the height (h) of nodes Y0 and Y1 leading to the three distinct *HSFY* lineages is estimated as 0.073 ± 0.011 and 0.055 ± 0.009 , respectively (see Methods). Thus, these gene lineages diverged 34–46 Mya in the stem lineage of Catarrhini (hominoids and OWMs).

RBMY and *TSPY*

As mentioned earlier, *RBMY* and *TSPY* possess their X-linked gametologs and multiple Y-linked copies in ampliconic seg-

ments. Here we confirm their proto-X/Y origins and examine the k_{XY} value between X and Y copies. In the next section, we examine these gene families with respect to their Y-chromosomal locations in P1, P3, and IR2 as well as in the *TSPY* array.

The *RBMX* family consists of six subfamilies (*RMBY1*–*6*) of ~30 genes and pseudogenes on both arms of the Y chromosome (Skaletsky et al. 2003) and exhibits sequence similarity with X-linked functional *RBMX* and intronless *RBMX2* as well as autosomal intronless *RBMXL*. Sequence similarity between *RBMX* subfamilies is as low as 60% even at the amino acid level, and some sequences in different subfamilies are difficult to align. For this reason, we used only *RBMX1* and *RBMX2* subfamilies. The phylogenetic analysis indicates an early dichotomous occurrence of mammalian *RBMX* and *RBMX2* (Fig. 3A). It is also clear that the X and Y differentiation predated the emergence of Metatherians (Delbridge et al. 1999) such that *RBMX* in *Macropus eugenii* and *Sminthopsis macroura* is orthologous to Eutherian *RBMX*. The k_{XY} value between *RBMX* and *RBMX2* is 0.681 ± 0.077 . It is smaller than the value given in Skaletsky et al. (2003). However, the previous report included an autosomal sequence (accession no. Z23064). Without this autosomal sequence, the estimated value becomes somewhat small, compared with that for *XKRY* and *HSFY* in stratum 1.

TSPY is the first gene that was isolated from any Y chromosome (Arnemann et al. 1987) and was subsequently found in

primates (Manz et al. 1993), artiodactyls (Jakubiczka et al. 1993), and rodents (Mazeyrat and Mitchell 1998). There are ~35 copies in the *TSPY* array (Skaletsky et al. 2003), several autosomal copies (*TSPYL2*), and one X-linked copy (*TSPX* previously designated as *TSPYL2*) under X inactivation (Delbridge et al. 2004). We examined 14 *TSPY* copies from humans together with *TSPY*, *TSPX*, and *TSPYL* orthologs from Eutherians. Although there is no obvious outgroup sequence in this data set, there exist two distinct clusters of *TSPY* and *TSPX/TSPYL*, and this dichotomy is consistent with the ancient origin hypothesis of X and Y copies (Fig. 3B). The k_{XY} value between *TSPX* and *TSPY* is 0.667 ± 0.103 (Table 3), as expected in stratum 2. In the stem lineage of Eutherians, intronless *TSPYL* was retroposed and duplicated such that various *TSPYL* genes exhibit multiple orthologous relationships among Eutherians. It is *TSPX* rather than *TSPY* that was retroposed so as to generate autosomal *TSPYL1*, 3, 4, 5, and 6 (Fig. 3B).

Ages of amplified copies and ampliconic structure

For a given gene family, there is a striking pattern in sequence similarity among copies within and between palindromes. All pairs of copies at symmetric arm positions within a palindrome are identical or nearly so (Skaletsky et al. 2003). However, not only may copies located between different palindromes be significantly different, but also different pairs within a palindrome may differ greatly. Two pairs of *XKRYP3/P6* and *XKRYP4/P5* within P1 differ from each other by nearly the same amount that they differ from *XKRYP1/P2* in P4 and *XKRY1/2* in P5 (Figs. 1 and 2A). The height of node Y0 (0.059 ± 0.010) in the linearized tree (Table 3) suggests that *XKRYP1/P2* in P4, *XKRY1/2* in P5, and two distinct pairs of *XKRYP3/P6* and *XKRYP4/P6* in P1 all diverged from one another 37 ± 6 Mya.

More informative and perplexing than the *XKRY* family is the *CDY* family. The *CDY* copies are scattered over different palindromes similar to *XKRY*, although more densely (Fig. 1). Consistent with the early retroposition of *CDY* (Dorus et al. 2003), we date the differentiation from *CDYL* as 159 ± 13 Mya (Fig. 4; Table 3). Subsequently in the primate lineage, the family expanded mostly in P1, P3, and P5. Four pairs of *CDY1A/1B*, *CDY9/P14*, *CDY10/P13*, and *CDY11/P12* in P1 are substantially different from each other, and so are three pairs of *CDY2A/2B*, *CDY2/P5*, and *CDY3/P4* in P5. In terms of node heights in the linearized tree, *CDY1A/1B* and *CDY10/P13* differ from each other by 0.048 ± 0.009 , these four differ from *CDY11/P12* by 0.058 ± 0.010 , and these six differ from the most distinct *CDY9/P14* by 0.139 ± 0.015 . We can find almost the same extent of sequence divergences among *CDY* copies in P5. Thus, the earliest divergence of *CDY* copies within P1 or P5 goes back to >80 Mya, and the latest is as old as 30 Myr.

RBMX and *TSPY* also provide useful information about the age of IR2 and the *TSPY* array, respectively (Fig. 1). The height of node Y0 between *RBMX2C/2D* in P1 and six nearly identical *RBMX1* copies in P3 and IR2 is 0.069 ± 0.008 (Table 3). The two subfamilies thus diverged 43 ± 5 Mya. *TSPY* underwent massive duplication independently in individual Eutherians, and some of 14 human *TSPY* copies exhibit ancient duplication. There exist distinct *TSPY2* and *TSPY13* within the *TSPY* array, as well as *TSPY14* located between P3 and IR2. The height of node Y0 leading to the most distinct *TSPY13* is 0.091 ± 0.009 (57 ± 6 Myr), and that of node Y1 and Y2 is 0.056 ± 0.007 (35 ± 4 Myr).

In short, major expansions of the gene families mentioned above occurred in the stem lineage of Catarrhini, 30–50 Mya.

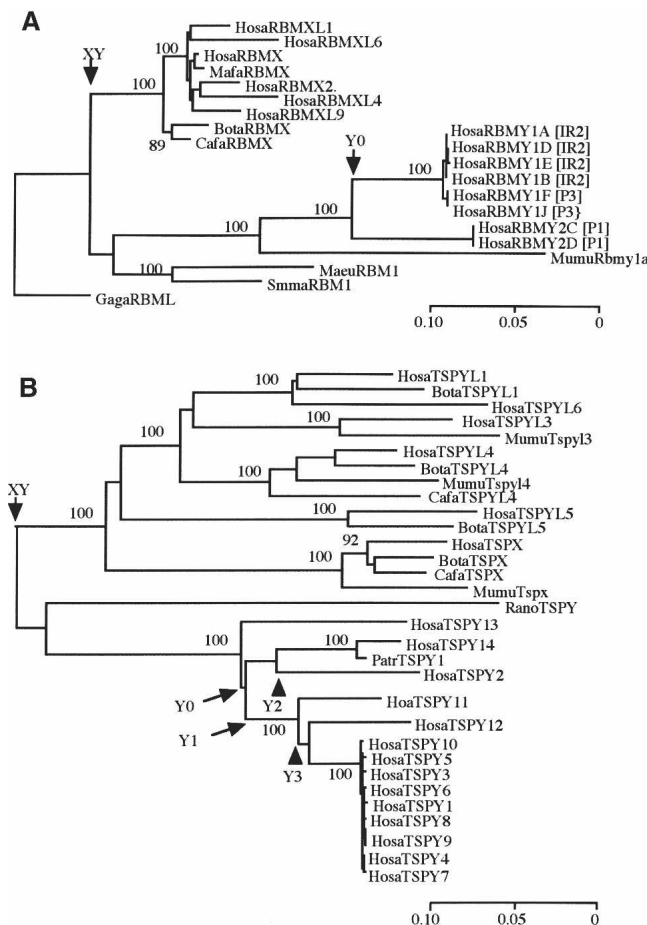

Figure 3. NJ trees of (A) *RBMX* and (B) *TSPY* drawn in the same way and with the same gene nomenclature system as in Figure 2. Ampliconic locations of human *RBMX* copies are indicated by bracketed P1, P3, and IR2.

Table 3. Ampliconic locations of Y genes, chromosomal locations (stratum) of X gametologs, XY or YL synonymous divergences, and heights of nodes estimated in linearized trees

	<i>XKRY</i>	<i>VCY</i>	<i>HSFY</i>	<i>RBMY</i>	<i>TSPY</i>	<i>CDY</i>
Location of Y copies	P1, P4, P5	P8	P4	P1, P3, IR2	<i>TSPY</i> array	P1, P3, P5
Location of X copy (stratum)	Xq22.1 (S1)	Xp22.3 (S4)	Xq28 (S1)	Xq26 (S1), Xq12 (S1)	Xp11.2 (S2)	Xp22.3 (S4)
Divergences						
XY	1.128 ± 0.236	0.189 ± 0.048	0.992 ± 0.294	0.681 ± 0.077	0.667 ± 0.103	
YL	0.120 ± 0.045		0.058 ± 0.039			0.477 ± 0.115
Nodes						
Y0	0.059 ± 0.010		0.073 ± 0.011	0.069 ± 0.008	0.091 ± 0.009	0.139 ± 0.015
Y1			0.055 ± 0.009		0.056 ± 0.007	0.092 ± 0.012
Y2					0.056 ± 0.007	0.066 ± 0.010
Y3					0.030 ± 0.005	0.058 ± 0.010
Y4						0.048 ± 0.009

(P) Palindrome; (IR) inverted repeat; [XY (YL)] the extent of synonymous divergences between gametologous X and Y (Y and L) copies with multiple-hit correction; (Y0–Y4) nodes and heights (*h*) in the linearized tree.

However, different palindromes and inverted repeats contain nearly identical copies as well. Like four *DAZ* genes in P1 and P2, mutually distinct *CDY1A/1B* and *CDYP11/P12* pairs in P1 are closely related to mutually distinct *CDY2A/2B* and *CDYP3/P4* pairs in P5, respectively (Figs. 1 and 4). Also, *CDYP7/P8* in P3 show high sequence similarity to *CDYP9/P14* in P1, and *RBMY1F/1J* in P3 are nearly identical to four other *RBMY1* copies in IR2. If such high sequence similarity is restricted to genetic loci, transposition or retroposition of genes is likely involved. A dot-plot analysis between P3 and IR2 indicates that sequence similarity is restricted to *RBMY1* loci (data not shown). Since these *RBMY1* copies show the same exon–intron structure, they are apparently related via recent duplicated transposition of genes. However, this is not the case for *DAZ* and *CDY*. Indeed, Kuroda-Kawaguchi et al. (2001) demonstrated that P1 shares distinct amplicons (massive repeat units) with P2 and P3, and proposed a model of

Alu-mediated tandem duplication and subsequent inversion for the P1 mosaicism.

After carrying out a dot-plot analysis, we aligned homologous sequences among palindromes, to show more precisely how and to what extent P1 is related to P2, P3, and P5, as well as P3 to P4 (Fig. 5). Several features are noteworthy. Above all, four amplicons in P1, which are nicknamed as *red*, *green*, *yellow*, and *blue* in Kuroda-Kawaguchi et al. (2001), are evolutionarily related to those in other palindromes. The *red* and *green* P1 amplicons are the same as the entire P2 region and a proximal, nonpalindromic region adjacent to P2, respectively (Kuroda-Kawaguchi et al. (2001). Using the aligned sequences over the *red* and *green* amplicons, we measured the per-site nucleotide differences (*P*) in non-overlapping windows of size 10 kb each. Except for a small *DAZ* encoding region in which *P* = 1% ~ 3%, the value is as low as ~0.1%. We can also find such a low *P*-value between a 170-kb *blue* P1 ampliconic unit and the corresponding region in P3. The *blue* P1 amplicon contains another 40-kb inverted region of P3 with *P* = 13% ~ 15%. Moreover, P3 and P4 share an ampliconic unit with *P* = 13% ~ 15%. The relationship of the *yellow* P1 amplicon to P5 is more complicated than that of the *blue* P1 amplicon. For convenience, the *yellow* P1 amplicon is divided into three units. Of these, one 200-kb unit (a thick black line in Fig. 5) has 92%–94% similarity to a 60-kb region of Chromosome 15 and ~80% similarity to 140-kb regions in some other chromosomes, but it does not have any homology with P5. Another 100-kb unit shows high similarity (*P* = 1% ~ 3%), and the remaining 460-kb unit is a tandem duplication of a 280-kb region of P5 (*P* = 13% ~ 15%). Thus, sequence similarity among ampliconic genes is a reflection of the P1 mosaicism with respect to P2, P3, P4, and P5.

Discussion

Out of seven families in human Y amplicons, we showed that five were derived from proto-X/Y gene pairs. The extent of synonymous divergences of these ampliconic genes from their X-linked gametologs differs greatly, depending on the latter chromosomal locations (Table 3). When an X-linked gametolog is located in stratum 1 (*XKRX*, *HSFX*, and *RBMX*), stratum 2 (*TSPX*), and stratum 4 (*VCX*), the differentiation between X and Y copies occurred more than 210, 180, and 50 Mya, respectively. Thus, the proto-X/Y-derived genes in the ampliconic class of euchromatic sequences began to differentiate at the same time as those in the

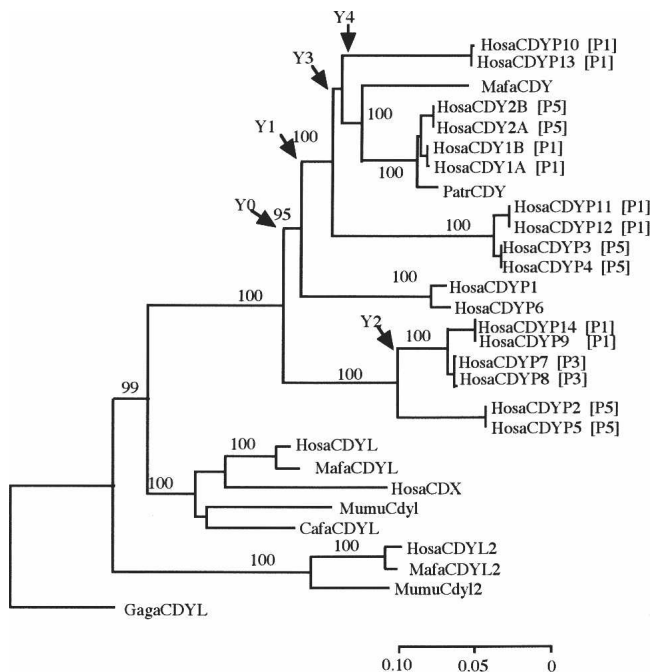

Figure 4. NJ tree of *CDY* drawn in the same way and with the same gene nomenclature system as in Figure 2. Palindromic locations of human *CDY* copies are indicated by bracketed P1, P3, and P5.

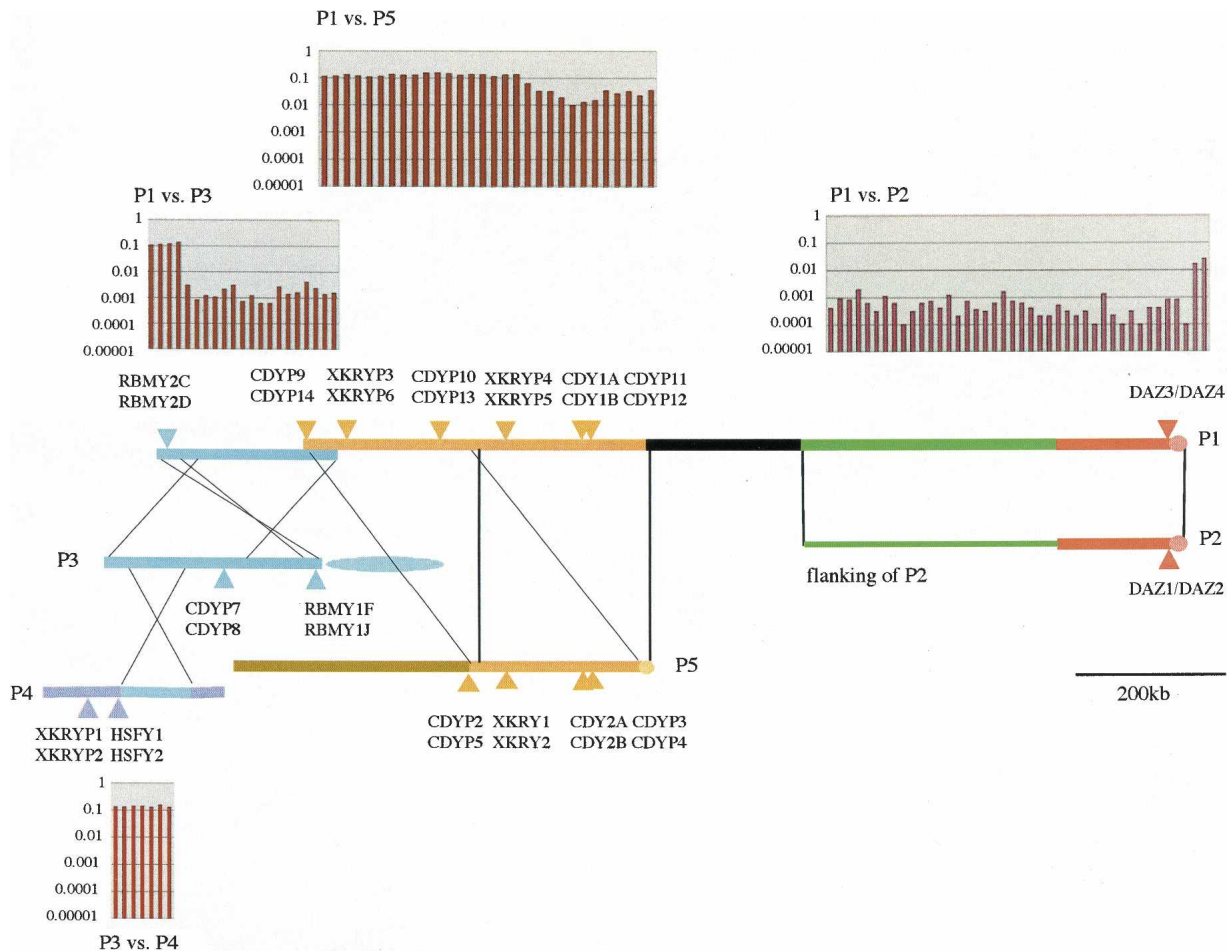

Figure 5. Sequence similarity of P1 against P2, P3, P4, and P5. The yellow amplicon in Kuroda-Kawaguchi et al. (2001) is divided into two: black, which has homology with autosomes, and yellow, which contains tandem duplication of a P5 ampliconic unit. Each thick line represents both arms in a palindrome, and a thin green line adjacent to P2 is nonpalindromic. Three nearly identical *BYP2* copies are located in the green ampliconic unit, and two distinct pairs of *PXY* copies are located in a blue ampliconic unit shared by P3 and P4. In non-overlapping windows of each size 10 kb, the nucleotide differences per site (P) between P1 and other palindromic amplicons are given above P1 and below P4. Note that the P -value (ordinate) is represented in common logarithms.

X-degenerate class, and both classes are relics of ancient autosomes (Skaletsky et al. 2003). However, these two classes of sequences and genes encoded therein were subjected to different fates. For instance, *AMELY* (Iwase et al. 2003) and *VCY* derived in XAR exemplify the difference: Whereas *AMELY* remains a single, housekeeping copy, *VCY* was duplicated so as to produce an identical pair in P8 and a testis-specific function. Incidentally, the presence of proto-X/Y-derived *VCY* in P8 implies per Ockham's razor that this palindrome cannot be older than the age of stratum 4, >50 Mya.

Transposition and retroposition of autosomal genes were once regarded as major mechanisms for generating ampliconic genes, but they actually contributed to generation of the *DAZ* and *CDY* gene families only. As discussed by Saxena et al. (1996, 2000), Agulnik et al. (1998), and Gromoll et al. (1999), a complete copy of autosomal *DAZL* was transposed on the Y chromosome in the stem lineage of Catarrhini, and the whole intron-containing transcript unit of this newly transposed gene (*DAZ*) was tetraplicated in P1 and P2. High sequence similarity between *DAZ1/2* in P2 and *DAZ3/4* in P1 (Fig. 5) indicate the hominoid or hominid-specific duplication or conversion between P1 and P2.

Likewise, the retroposition origin is unique to *CDY* (Lahn and Page 1997, 1999a; Dorus et al. 2003). However, the presence of intron-containing *CDX*, annotated as a pseudogene in NCBI (Build 36.1), is enigmatic. Sequence similarity between the 5' portion of *CDX* and mature *CDYL* transcripts suggests that *CDX* arose via duplicated transposition of *CDYL* (Fig. 4). If the transposition occurred after the formation of stratum 4, *CDX* is likely to be specific to the X chromosome. In the opposite situation, the transposition could generate an intron-containing *CDY* copy, as the sex chromosomal differentiation proceeded in stratum 4. In either case, retroposition and transposition of autosomal genes played relatively minor roles in originating ampliconic genes. However, the reverse process occurred more frequently. Transposition of *XKRY* produced *XKRYL*, and retroposition of *HSFY*, *RBMX*, and *TSPX* produced *HSFYL*, *RBMXL*, and *TSPYL* (more logically designated as *TSPXL*), respectively. Since the latter three genes are highly expressed in germ-cell lines, transcripts have ample opportunity to be retroposed and integrated into the genome (Zhang and Gerstein 2004; Cheng et al. 2005).

Unlike the X-degenerate segments, the ampliconic segments underwent massive amplifications during primate evolution. We

showed that most distinct copies in *XKRY*, *HSFY*, *RBMV*, *TSPY*, and *CDY* families were established in the stem lineage of Catarrhini. There are two notable features in the pattern and degree of sequence identity among those copies. First, within a palindrome, we can always find two nearly identical copies of a given gene family at symmetric arm positions (Skaletsky et al. 2003), yet copies at different arm positions are substantially different from each other. Palindrome P1 harbors two such paired *XKRY* and four such paired *CDY* copies in our data set. The estimated ages of these paired copies are similar and older than 30 Myr irrespective of gene families. Palindrome P5 harbors three such paired *CDY*. Again, these paired copies in P5 are as distinct as those in P1. Second, there are paired copies that are identical or nearly so even when they are located in different palindromes P1, P2, P3, P5, and/or IR2 (Figs. 3 and 4). Such high sequence similarity among copies compelled us to extend our analyses. As mentioned, the previous dot-plot analysis for P1, P2, and P3 indicated the elaborate mosaicism of P1 (Kuroda-Kawaguchi et al. 2001). We further found that (1) P1 and P3 are also related to P5 and P4, respectively; (2) some P1 amplicons are reticulately related to other palindromes via small shared ampliconic units; and (3) sequence similarity among gene copies is well correlated with that among those ampliconic units (Fig. 5).

The mosaicism of P1 is so extensive that >80% of P1 is related directly to P2, P3, and P5 and indirectly to P4. The observed *P*-values (per-site nucleotide differences) indicate three distinct levels of evolutionary relatedness of ampliconic units between different palindromes; the lowest level of $P < 0.1\%$ in the *red*, *green*, and *blue* amplicons, the middle level of $P = 1\% \sim 3\%$ in the *red* and *yellow* amplicons, and the highest level of $P = 13\% \sim 15\%$ in the *yellow* and *blue* amplicons. The *yellow* amplicon in P1 also contains a *black* ampliconic unit (Fig. 5) that is totally unrelated to any other palindrome in the Y chromosome. Rather, a subregion of the *black* ampliconic unit encoding transcription units *CSPG4LY* and *GOLGA2LY* (Kuroda-Kawaguchi et al. 2001; Skaletsky et al. 2003) is closely related to a region in chromosome 15 ($P < 5\%$), whereas the remaining subregions show the *P*-values of $\sim 20\%$ with various chromosomes. It is conceivable that P1 originally consisted of a small region and then repeatedly acquired other ampliconic units in P2, P3, P5, and autosomes or that P1 simply exchanged ampliconic sequences without substantial expansion in its size. In either case, the extent of sequence differences in Figure 5 dates the earliest sequence acquisition or exchange as ~ 50 Mya in the stem lineage of Catarrhini, the second as 3–9 Mya in the hominid or hominoid lineage, and the latest as < 0.3 Mya in modern humans. Rozen et al. (2003) reported the presence of P1 in chimpanzees and bonobos. However, since they examined two inner and outer boundaries of a palindrome, the internal palindromic structure is not known in these and other apes. It is extremely unlikely that these relatives possess the same *red* and *green* P1 ampliconic structure as humans do. Also, it is questionable if the *yellow* and *blue* P1 amplicons in chimpanzees are the same as those in humans.

In conclusion, owing to extensive sequence transfers of ampliconic units, the age of a palindrome differs from region to region. Nonetheless, the age of an ampliconic unit is well correlated with the age of genes encoded therein. Undoubtedly, like genes, major ampliconic units must have been established in the stem lineage of Catarrhini. While these repeat units have since evolved en bloc, palindromes have been extensively modified by acquisition and/or exchange of repeat units in other palindromes. It would be surprising if such modifications in ampli-

conic gene contents and structures had nothing to do with changes in spermatogenesis or sperm production in the lineage leading from the Catarrhini ancestor to modern humans. Indeed, the *AZFc* (azoospermia factor c) region, whose deletion is known as the most common cause of spermatogenic failure in humans, largely consists of P1 and P2 (Kuroda-Kawaguchi et al. 2001). Our finding that P2 is quantitatively similar to and qualitatively redundant to P1 may imply that evolution of P1 has played critical roles in developing human-specific spermatogenesis.

Methods

Our analysis is based on DNA sequence data in the NCBI genome database as of July 31, 2006. We retrieved DNA sequences of the nine ampliconic genes and related pseudogenes from the human genome database. At the same time, we located them in the Y chromosome based on information about locus positions in contigs as well as results of DOTTER and Map Viewer after BLASTN. We also used DOTTER to examine sequence similarity between different amplicons. The current chromosomal locations of the ampliconic genes in the NCBI Master Map appear slightly different from the initial proposal by Skaletsky et al. (2003). Using BLASTN and GENE, we searched for X-linked and autosomal copies for a given gene family. Some genes homologous to human ampliconic genes can be found even in fish. However, we did not use distantly related orthologs in our analysis because the origin of the primate Y chromosome surely postdated the divergence between mammals and birds.

To designate an ortholog in figures, we use a four-letter prefix to identify the genus and species names. For example, *XKRY* in humans (*Homo sapiens*) and chimpanzees (*Pan troglodytes*) is designated as *HosaXKRY* and *PatrXKRY*, respectively. Autosomal genes and pseudogenes are indicated by addition of the suffix *L* or *P*, respectively. When there are multiple human Y-linked pseudogenes in a given gene family, those without official names are numbered from the short arm end of the Y (Fig. 1; see also Kuroda-Kawaguchi et al. 2001). The sequence alignments are given in Supplemental Figure 1.

For phylogenetic analyses, we use the coding regions only to minimize misalignments among distantly related and rapidly evolving Y-linked sequences. However, some genes, such as *DAZ*, contain repeated exons or tandem repeats that underwent extensive expansions and contractions. We exclude such repeats, as our main purpose is to comprehend the evolutionary relationships among Y-linked, X-linked, and autosomal copies when they are present. We use the NJ method by Saitou and Nei (1987) to determine the topology as well as the method by Takezaki et al. (1995) to determine the height (*h*) of a specified node in the linearized tree. However, regarding node XY at which X and Y gametologs differentiate, we cannot use the linearized tree method because these gametologs apparently evolved with different rates. We apply the same caution to node YL at which Y-linked and autosomal copies differentiate via transposition or retroposition. We simply compute the sequence divergences per synonymous site (k_{XY} or k_{YL}) after multiple-hit corrections (Jukes and Cantor 1969; Kimura 1980). To date, for XY, YL, or other nodes in Figures 2 and 3, we use the silent nucleotide substitution rate per site per year of $r_L = 1.0 \times 10^{-9}$ for the autosomes, $r_X = 0.83 \times 10^{-9}$ for the X chromosome, and $r_Y = 1.6 \times 10^{-9}$ for the Y chromosome (Ebersberger et al. 2002). These are estimated by the 1.2%, 1.0%, and 1.9% sequence divergences between the human and chimpanzee chromosomes, respectively, and the as-

sumption of the 6-Myr species divergence time (Haile-Selassie 2001). Applying these rates to k_{XY} , we date node XY as

$$t_{XY} = k_{XY}/((1 + \alpha)r_X)$$

where α is the ratio of r_Y to r_X . If we assume $\alpha = 2$ (Ebersberger et al. 2002), the t_{XY} value is given by $k_{XY}/(3r_X)$ rather than $k_{XY}/(2r_X)$ under the assumption of $r_Y = r_X$. Similarly, we date node YL by

$$t_{YL} = 2k_{YL}/((1 + 3\alpha)r_X).$$

Regarding the height (h) of a node leading to a group of Y-linked copies, we date the node simply by

$$t = h/r_Y.$$

Acknowledgments

This work was supported in part by the Japan Society for Promotion of Science Grants 12304046 to N.T., and MEXT scholarship assistance to B.K.B.

References

- Agulnik, A.I., Zharkikh, A., Boettger-Tong, H., Bourgeron, T., McEireavey, K., and Bishop, C.E. 1998. Evolution of the *DAZ* gene family suggests that Y-linked *DAZ* plays little, or a limited, role in spermatogenesis but underlines a recent African origin for human populations. *Hum. Mol. Genet.* **7**: 1371–1377.
- Arnemann, J., Epplen, J.T., Cooke, H.J., Sauermann, U., Engel, W., and Schmidtke, J. 1987. A human Y-chromosomal DNA sequence expressed in testicular tissue. *Nucleic Acids Res.* **15**: 8713–8724.
- Chai, N.-N., Zhou, H., Hernandez, J., Najmabadi, H., Bhasin, S., and Yen, P.H. 1998. Structure and organization of the *RBM1* genes on the human Y chromosome: Transposition and amplification of an ancestral autosomal *hnRNP* gene. *Genomics* **49**: 283–289.
- Cheng, J., Kapranov, P., Drenkow, J., Dike, S., Brubaker, S., Patel, S., Long, J., Stern, D., Tammanna, H., Helt, G., et al. 2005. Transcriptional maps of 10 human chromosomes at 5-nucleotide resolution. *Science* **308**: 1149–1154.
- Delbridge, M.L., Harry, J.L., Toder, R., O'Neill, R.J., Ma, K., Chandley, A.C., and Graves, J.A.M. 1997. A human candidate spermatogenesis gene, *RBM1*, is conserved and amplified on the marsupial Y chromosome. *Nat. Genet.* **15**: 131–136.
- Delbridge, M.L., Ma, K., Subbarao, M.N., Cooke, H.J., Bhasin, S., and Graves, J.A.M. 1998. Evolution of mammalian *HNRPG* and its relationship with the putative azoospermia factor *RBM*. *Mamm. Genome* **9**: 168–170.
- Delbridge, M.L., Lingenfelter, P.A., Disteche, C.M., and Graves, J.A.M. 1999. The candidate spermatogenesis gene *RBM1* has a homolog on the human X chromosome. *Nat. Genet.* **22**: 223–224.
- Delbridge, M.L., Longepied, G., Depetris, D., Mattei, M.-G., Disteche, C., Graves, J.A.M., and Mitchell, M.J. 2004. *TSPY*, the candidate gonadoblastoma gene on the human Y chromosome, has a widely expressed homologue on the X—Implications for Y chromosome evolution. *Chromosome Res.* **12**: 345–356.
- Dorus, S., Gilbert, S.L., Foster, M.L., Foster, M.L., Barndt, R.J., and Lahn, B. 2003. The *CDY*-related gene family: Coordinated evolution in copy number, expression profile and protein sequence. *Hum. Mol. Genet.* **12**: 1643–1650.
- Ebersberger, I., Metzler, D., Schwarz, C., and Pääbo, S. 2002. Genomewide comparison of DNA sequences between humans and chimpanzees. *Am. J. Hum. Genet.* **70**: 1490–1497.
- Elliott, D.J., Venables, J.P., Newton, C.S., Lawson, D., Boyle, S., Eperon, I.C., and Cooke, H.J. 2000. An evolutionarily conserved germ cell-specific *hnRNP* is encoded by a retrotransposed gene. *Hum. Mol. Genet.* **9**: 2117–2124.
- Fukami, M., Kirsch, S., Schiller, S., Richter, A., Benes, V., Franco, B., Muroya, K., Rao, E., Merker, S., Niesler, B., et al. 2000. A member of a gene family on Xp23.3, *VCX-A*, is deleted in patients with X-linked nonspecific mental retardation. *Am. J. Hum. Genet.* **67**: 563–573.
- Graves, J.A.M. 1995. The origin and function of the mammalian Y chromosome and Y-borne genes—An evolving understanding. *Bioessays* **17**: 311–320.
- Graves, J.A.M. 2002. The rise and fall of *SRY*. *Trends Genet.* **18**: 259–264.
- Gromoll, J., Weinbauer, G.F., Skaletsky, H., Schlatt, S., Rocchietti-March, M., Page, D.C., and Niesclag, E. 1999. The Old World monkey *DAZ* (Deleted in Azoospermia) gene yields insights into the evolution of the *DAZ* gene cluster on the human Y chromosome. *Hum. Mol. Genet.* **8**: 2017–2024.
- Haile-Selassie, Y. 2001. Late Miocene hominids from the middle Awash, Ethiopia. *Nature* **412**: 178–181.
- Hughes, J.F., Skaletsky, H., Pyntikova, T., Minx, P.J., Graves, T., Rozen, S., Wilson, R.K., and Page, D.C. 2005. Conservation of Y-linked genes during human evolution revealed by comparative sequencing in chimpanzee. *Nature* **437**: 101–104.
- Iwase, M., Satta, Y., Hirai, Y., Hirai, H., Imai, H., and Takahata, N. 2003. Differentiation of sex chromosomal amelogenin genes in primates and other mammals. *Proc. Natl. Acad. Sci.* **100**: 5258–5263.
- Jakubiczka, S., Schnieders, F., and Schmidtke, J. 1993. A bovine homologue of the human *TSPY* gene. *Genomics* **17**: 732–735.
- Jukes, T.H. and Cantor, C.R. 1969. Evolution of protein molecules. In *Mammalian protein metabolism* (ed. H.N. Munro), pp. 21–132. Academic Press, New York.
- Kimura, M. 1980. A simple method for estimating evolutionary rates of base substitutions through comparative studies of nucleotide sequences. *J. Mol. Evol.* **16**: 111–120.
- Kumar, S. and Hedges, S.B. 1998. A molecular timescale for vertebrate evolution. *Nature* **392**: 917–920.
- Kuroda-Kawaguchi, T., Skaletsky, H., Brown, L.G., Minx, P.J., Cordum, H.S., Waterston, R.H., Wilson, R.K., Silber, S., Oates, R., Rozen, S., et al. 2001. The *AZFc* region of the Y chromosome features massive palindromes and uniform recurrent deletions in infertile men. *Nat. Genet.* **29**: 279–286.
- Kuroki, Y., Toyoda, A., Noguchi, H., Taylor, T.D., Itoh, T., Kim, D.S., Kim, D.W., Choi, S.H., Kim, I.C., Choi, H.H., et al. 2006. Comparative analysis of chimpanzee and human Y chromosomes unveils complex evolutionary pathway. *Nat. Genet.* **38**: 158–167.
- Lahn, B.T. and Page, D.C. 1997. Functional coherence of the human Y chromosome. *Science* **278**: 675–680.
- Lahn, B.T. and Page, D.C. 1999a. Retroposition of autosomal mRNA yielded testis-specific gene family on human Y chromosome. *Nat. Genet.* **21**: 429–433.
- Lahn, B.T. and Page, D.C. 1999b. Four evolutionary strata on the human X chromosome. *Science* **286**: 964–967.
- Lahn, B.T. and Page, D.C. 2000. A human sex-chromosomal gene family expressed in male germ cells and encoding variably charged proteins. *Hum. Mol. Genet.* **9**: 311–319.
- Lingenfelter, P.A., Delbridge, M.L., Thomas, S., Hoeksstra, H.E., Mitchell, M.J., Graves, J.A.M., and Disteche, C.M. 2001. Expression and conservation of processed copies of the *RBMX* gene. *Mamm. Genome* **12**: 538–545.
- Manz, E., Schnieders, F., Brechlin, A.M., and Schmidtke, J. 1993. *TSPY*-related sequences represent a microheterogeneous gene family organized as constitutive elements in *DYZ5* tandem repeat units on the human Y chromosome. *Genomics* **17**: 726–731.
- Martin, R.D. 1993. Primate origins: Plugging the gaps. *Nature* **363**: 223–234.
- Mazeyrat, S. and Mitchell, M.J. 1998. Rodent Y chromosome *TSPY* gene is functional in rat and non-functional in mouse. *Hum. Mol. Genet.* **7**: 557–562.
- Ohno, S. 1967. *Sex chromosomes and sex-linked genes*. Springer, Berlin-Heidelberg-New York.
- Ross, M.T., Grafham, D.V., Coffey, A.J., Coffey, A.J., Scherer, S., McLay, K., Muzny, D., Platzer, M., Howell, G.R., Burrows, C., et al. 2005. The DNA sequence of the human X chromosome. *Nature* **434**: 325–336.
- Rozen, S., Skaletsky, H., Marszalek, J.D., Minx, P.L., Cordum, H.S., Waterston, R.H., Wilson, R.K., and Page, D.C. 2003. Abundant gene conversion between arms of palindromes in human and ape Y chromosomes. *Nature* **423**: 873–876.
- Saitou, N. and Nei, M. 1987. The neighbor-joining method: A new method for reconstructing phylogenetic trees. *Mol. Biol. Evol.* **4**: 406–425.
- Saxena, R., Brown, L.G., Hawkins, T., Alagappan, R.K., Skaletsky, H., Reeve, M.P., Reijo, R., Rozen, S., Dinulos, M.B., Disteche, C.M., et al. 1996. The *DAZ* gene cluster on the human Y chromosome arose from an autosomal gene that was transposed, repeatedly amplified and pruned. *Nat. Genet.* **14**: 292–299.
- Saxena, R., de Vries, J.W.A., Repping, S., Alagappan, R.K., Skaletsky, H., Brown, L.G., Ma, P., Chen, E., Hoovers, J.M., and Page, D.C. 2000. Four *DAZ* genes in two clusters found in the *AZFc* region of the human Y chromosome. *Genomics* **67**: 256–267.
- Schnieders, F., Dork, T., Arnemann, J., Vogel, T., Werner, M., and Schmidtke, J. 1996. Testis-specific protein, Y-encoded (*TSPY*) expression in testicular tissues. *Hum. Mol. Genet.* **5**: 1801–1807.
- Skaletsky, H., Kuroda-Kawaguchi, T., Minx, P.J., Cordum, H.S., Hillier,

- L., Brown, L.G., Repping, S., Pyntikova, T., Ali, J., Bieri, T., et al. 2003. The male-specific region of the human Y chromosome is a mosaic of discrete sequence classes. *Nature* **423**: 825–837.
- Stouffs, K., Lissens, W., Landuyt, L.V., Tournaye, H., Steirteghem, A.V., and Liebaers, I. 2001. Characterization of the genomic organization, localization and expression of four PRY genes (*PRY1*, *PRY2*, *PRY3* and *PRY4*). *Mol. Hum. Reprod.* **17**: 603–610.
- Takahata, N. 2001. Molecular phylogeny and demographic history of humans. In *Humanity from African Naissance to coming millennia* (ed. P.V. Tobias et al.), pp. 299–305. Witwatersrand University Press, Johannesburg, South Africa.
- Takezaki, N., Rzhetsky, A., and Nei, M. 1995. Phylogenetic test of the molecular clock and linearized tree. *Mol. Biol. Evol.* **12**: 823–833.
- Tessari, A., Salata, E., Ferlin, A., Bartoloni, L., Slongo, M.L., and Foresta, C. 2004. Characterization of *HSPY*, a novel *AZFb* gene on the Y chromosome with a possible role in human spermatogenesis. *Mol. Hum. Reprod.* **10**: 253–258.
- Waters, P.D., Delbridge, M.L., Deakin, J.E., El-Mogharbel, N., Kirby, P.J., Carvalho-Silva, D.R., and Graves, J.A.M. 2005. Autosomal location of genes from the conserved mammalian X in the platypus (*Ornithorhynchus abatinus*): Implication for mammalian sex chromosome evolution. *Chromosome Res.* **13**: 401–410.
- Zhang, Z. and Gerstein, M. 2004. Large-scale analysis of pseudogenes in the human genome. *Curr. Opin. Genet. Dev.* **14**: 328–335.
- Zou, S.W., Zhang, J.C., Zhang, X.D., Miao, S.Y., Zong, S.H., Sheng, Q., and Wang, L.F. 2003. Expression and localization of *VCX/Y* proteins and their possible involvement in regulation of ribosome assembly during spermatogenesis. *Cell Res.* **13**: 171–177.

Received July 6, 2006; accepted in revised form November 1, 2006.