



Conservation of Microstructure between a Sequenced Region of the Genome of Rice and Multiple Segments of the Genome of *Arabidopsis thaliana*

Klaus Mayer, George Murphy, Renato Tarchini, et al.

Genome Res. 2001 11: 1167-1174

Access the most recent version at doi:[10.1101/gr.161701](https://doi.org/10.1101/gr.161701)

License

Email Alerting Service

Receive free email alerts when new articles cite this article - sign up in the box at the top right corner of the article or [click here](#).

An advertisement banner with a teal background. On the left, the text reads "CRISPR and RNAi Genetic Screening. Your new superpower." In the center, there is a white button with the text "LEARN MORE". On the right, there is a photograph of a woman wearing a red superhero mask and cape, and the Cellecta logo, which consists of a cluster of green dots and the word "CELLECTA" below it.

To subscribe to *Genome Research* go to:
<https://genome.cshlp.org/subscriptions>

Cold Spring Harbor Laboratory Press

Conservation of Microstructure between a Sequenced Region of the Genome of Rice and Multiple Segments of the Genome of *Arabidopsis thaliana*

Klaus Mayer,¹ George Murphy,² Renato Tarchini,^{3,11} Rolf Wambutt,⁴ Guido Volckaert,⁵ Thomas Pohl,⁶ Andreas Düsterhöft,⁷ Willem Stiekema,⁸ Karl-Dieter Entian,⁹ Nancy Terry,¹⁰ Kai Lemcke,¹ Dirk Haase,¹ Caroline R. Hall,² Anne-Marie van Dodeweerd,² Scott V. Tingey,³ Hans-Werner Mewes,¹ Michael W. Bevan,² and Ian Bancroft^{2,12}

¹National Research Center for Environment and Health, Institute for Bioinformatics, Munich Information Centre for Protein Sequences, 85764 Neuherberg, Germany; ²John Innes Centre, Colney, Norwich, NR7 4UH, United Kingdom; ³DuPont Agricultural Biotechnology, Newark, Delaware 19711, USA; ⁴AGOWA GmbH, D-12489 Berlin, Germany; ⁵Katholieke Universiteit Leuven, Laboratory of Gene Technology, B-3001 Leuven, Belgium; ⁶GATC GmbH, D-78467 Konstanz, Germany; ⁷QIAGEN GmbH, Max-Volmer-Str.4, D-40724 Hilden, Germany; ⁸Plant Research International, NL 6708 PB, Wageningen, The Netherlands; ⁹Institut für Mikrobiologie, D-60439 Frankfurt/M., Germany; ¹⁰Department of Genetics, University of Ghent, B-9000 Ghent, Belgium

The nucleotide sequence was determined for a 340-kb segment of rice chromosome 2, revealing 56 putative protein-coding genes. This represents a density of one gene per 6.1 kb, which is higher than was reported for a previously sequenced segment of the rice genome. Sixteen of the putative genes were supported by matches to ESTs. The predicted products of 29 of the putative genes showed similarity to known proteins, and a further 17 genes showed similarity only to predicted or hypothetical proteins identified in genome sequence data. The region contains a few transposable elements: one retrotransposon, and one transposon. The segment of the rice genome studied had previously been identified as representing a part of rice chromosome 2 that may be homologous to a segment of *Arabidopsis* chromosome 4. We confirmed the conservation of gene content and order between the two genome segments. In addition, we identified a further four segments of the *Arabidopsis* genome that contain conserved gene content and order. In total, 22 of the 56 genes identified in the rice genome segment were represented in this set of *Arabidopsis* genome segments, with at least five genes present, in conserved order, in each segment. These data are consistent with the hypothesis that the *Arabidopsis* genome has undergone multiple duplication events. Our results demonstrate that conservation of the genome microstructure can be identified even between monocot and dicot species. However, the frequent occurrence of duplication, and subsequent microstructure divergence, within plant genomes may necessitate the integration of subsets of genes present in multiple redundant segments to deduce evolutionary relationships and identify orthologous genes.

Rice (*Oryza sativa*) is a widely grown crop, and is the staple food for over one-half of the world's population. Extensive classical and molecular genetic maps have been constructed to assist biological analyses and plant breeding applications (Kinoshita 1995; Kurata et al. 1994). The genome size of rice, ~440 Mb (Arumuganathan and Earle 1991), is one of the smallest of the cereals. It has been postulated that the genes

within the genome of rice, as with the genes of other *Gramineae*, are clustered in gene-rich regions separated by gene-poor DNA (Barakat et al. 1997). A high degree of conservation of the order of gene-specific markers (conserved synteny) has been observed between the genomes of most cereals, including rice (Moore et al. 1995). The sequences of exons and exon-intron structures of orthologous genes in the *sh2/a1*-homologous regions of rice and sorghum have been shown to be conserved (Chen et al. 1998). However, more divergence of gene content has been found in the *Adh1* regions of the genomes of maize and sorghum (Tikhonov et al. 1999). Nevertheless, rice is being developed as the key model monocot species for molecular genetic investigations, with the expectation that, by exploiting conserved synteny, the identification and functional assign-

¹¹Present address: Plant Research International, Droevendaalsesteeg 1, 6708 PB, Wageningen, The Netherlands.

¹²Corresponding author.

E-MAIL ian.bancroft@bbsrc.ac.uk; FAX: 44 1603 259882.

Article published on-line before print: *Genome Res.*, 10.1101/gr.161701.
Article and publication are at <http://www.genome.org/cgi/doi/10.1101/gr.161701>.

ment of genes in rice will lead to the identification of the equivalent genes in other cereal species. These applications are being supported by the Rice Genome Project, which commenced in 1991. The main aim of this project is the determination of the complete nucleotide sequence of the rice genome.

A 340-kb region around the rice *Adh1-Adh2* region has been sequenced (Tarchini et al. 2000), and is predicted to contain 33 protein-coding genes. Fourteen of these predicted genes were supported by the identification of corresponding transcripts, and 15 genes were similar in structure to genes with known functions. Nineteen of the 33 genes were members of gene families within the sequenced region, although some copies were predicted to be nonfunctional pseudogenes.

The key model dicot plant species is *Arabidopsis thaliana* (*Arabidopsis*). Extensive classical genetic, molecular genetic, and physical maps have been developed, along with numerous genome analysis and gene cloning strategies (Koornneef 1990; Lister and Dean 1993; Feldmann et al. 1989; Giraudat et al. 1992; Bancroft et al. 1993; Schmidt et al. 1995; http://nasc.nott.ac.uk/new_ri_map.html). The *Arabidopsis* genome has been completely sequenced (The *Arabidopsis* Genome Initiative 2000). It is very gene-rich, containing 25,498 genes, with an average density of one gene per 4.5 kb. Conservation of gene order has been observed between segments of the genome of *Arabidopsis* and those of its closest relatives among crops, the cultivated *Brassica* species (Kowalski et al. 1994; Cavell et al. 1998; Lagercrantz 1998).

It had been predicted that conserved synteny between

the genomes of *Arabidopsis* and cereals, which diverged ca. 200 million years ago (Wolfe et al. 1989), would be detectable for segments of ~3 cM (Paterson et al. 1996). Such conservation could lead to the use of positional approaches to integrate functional genomics information from both monocot and dicot species. The results of comparative genetic mapping efforts have provided little evidence for conserved gene organization (Gale and Devos 1998). Although some conserved synteny can be detected between the genomes of rice and *Arabidopsis* using physical mapping and sequence analysis approaches, the extent of conservation appears low (Devos et al. 1999; Han et al. 1999; van Dodeweerd et al. 1999). In the present study we report the results of a pilot-scale rice genome sequencing project and the use of the data to further study aspects of genome organization in *Arabidopsis*.

RESULTS

Gene Prediction

Four overlapping BACs representing the 340-kb region to be sequenced had been identified previously (van Dodeweerd et al. 1999). A shotgun sequencing strategy was used and annotation performed on a 339,972-bp contiguous assembly as submitted to EMBL (accession no. AJ307662). Four gene prediction programs were used for modeling exon structure: Genemark.hmm, FGENESH, Genscan, and GeneFinder. Comparisons of the outputs from these programs with gene structures determined using EST matches and protein homologies for three genes are shown in Figure 1. Although all

programs correctly predicted the presence of a gene, none of the predictions accurately identified the exon-intron structures of the genes.

Gene prediction in rice is complicated by the fact that a rice species setting is available only for Genemark.hmm. Nevertheless, our data suggest that even Genemark.hmm output is not reliable enough to perform an *in silico* whole-genome analysis in rice. Further adjustment and refinement of gene prediction programs is necessary for large-scale automated genome analysis. Similarities of genomic sequences with EST sequences, matches of predicted protein products with known proteins, and matches with transposable elements were also used to derive the final gene modeling, as shown in Figure 2. In total, 56 potential protein-coding genes were identified, along with a region containing a retrotransposon and a region showing homology to transposon Tnr1. Two tRNAs were also identified. A summary of the positions of the identified genes and other features is presented in Table 1.

Identification of Homologous ESTs and Proteins

The rice genomic nucleotide sequence was used to query a rice EST database to identify ESTs corresponding to modeled genes. A threshold of at least 90% sequence identity over at least 150 bp was applied. Each predicted gene was used to query all available

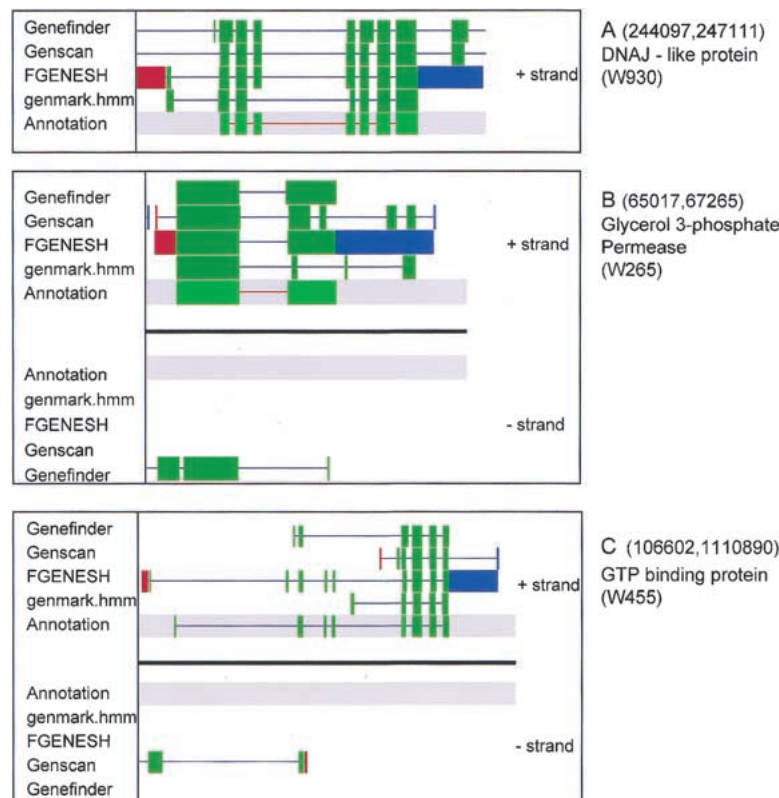

Figure 1 Comparison of gene models predicted by Genemark.hmm, FGENESH, Genscan, and GeneFinder for predicted genes W930 (A), W265 (B), and W455 (C). Green boxes denote predicted as well as annotated protein coding regions.

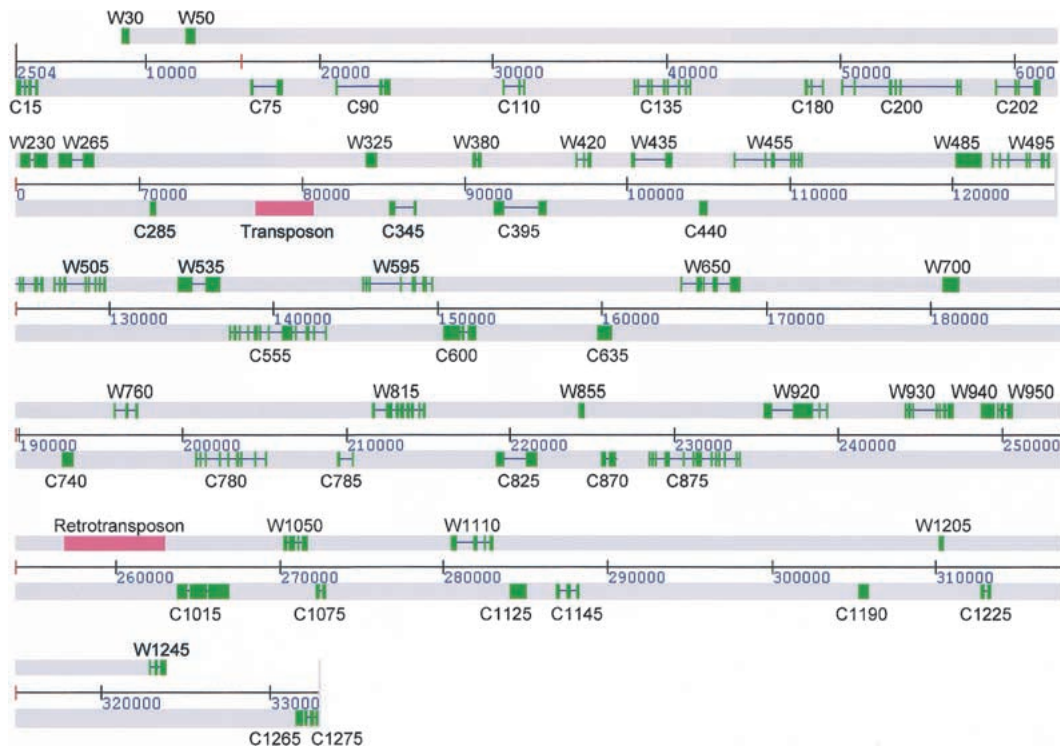

Figure 2 Positions of predicted genes (predicted protein coding regions denoted by green boxes) and transposable elements (red boxes).

nucleotide and protein databases for homologous identified or predicted protein sequences. The results of both analyses are summarized in Table 1. Sixteen of the 56 modeled genes match ESTs, supporting the prediction of the presence of a gene. The predicted proteins of 29 putative genes (52%) match known proteins, and the predicted proteins of 17 putative genes (30%) match proteins predicted from genome sequence data. The predicted proteins of the 10 remaining putative genes (18%) show no similarity to known proteins, so may either represent new types of proteins or be the result of false gene predictions.

The predicted proteins for all 56 putative genes were analyzed for the presence of functional domains using Interpro (The InterPro Consortium 2000). The results are shown in Table 2. Characterized functional domains of protein products were identified for 33 of the 56 putative genes (59%). These allowed us to identify a four-member gene family (C635, W700, W940, and C1190) encoding protein products with AP2 domain/ethylene responsive element binding protein functional domains, which was the largest gene family we identified in the sequenced region.

Analysis of Genome Organization in Rice and *Arabidopsis*

The extent of conservation of both the presence and the position of genes in the sequenced segment of the rice genome and the corresponding segments of the genome of *Arabidopsis* was analyzed. BLASTP analyses were performed using the extracted amino acid sequences of the annotated rice genes to query a database of all predicted *Arabidopsis* protein sequences, using a P -value of $\leq e^{-5}$ as a cutoff. The results were

then filtered to remove adjacent matches (indicative of tandem duplications) and clusters of three or more nearby matches recorded. The results for this analysis of the 340-kb region are summarized in Table 3. The relative coding strand for each gene model is denoted by W or C. Five segments of the *Arabidopsis* genome contained conserved subsets of the rice genes, as shown in Figure 3. These segments represented regions of the *Arabidopsis* genome containing approximately 22, 27, 20, 15, and 23 genes, for the chromosome 4(a), 5, 2, 4(b), and 3 segments, respectively, shown in Figure 3. Overall, 22 of the 56 rice genes are represented in the five *Arabidopsis* chromosome segments, counting both copies of three pairs of related genes (W495/W505, C635/W700, and W940/C1190) that show homology to common *Arabidopsis* genes. The most highly conserved segment, chromosome 4(a), contains eight conserved genes, with one pair (W950-AT4g17340 and W1050-AT4g17350) reversed. The relative coding strand orientation of the genes is also conserved, except for the reversal of the final pair, which is consistent with the inversion of the segment containing the genes. This region of the *Arabidopsis* genome had been shown previously to be related to the sequenced segment of the rice genome (van Dodeweerd et al. 1999). The *Arabidopsis* chromosome 5 segment contains seven conserved genes. These are also in conserved order and orientation, except the same reversed pair of genes. This region of the *Arabidopsis* genome had been shown previously to be related to the chromosome 4(a) segment (Bancroft 2000). The remaining segments contain seven, five, and five conserved genes for the chromosome 2, 4(b), and 3 segments, respectively, all in conserved order. However, the orientation of several of the individual genes is reversed, indicating possible small-scale inversion events.

Table 1. Features Identified in Rice Sequence Data

Feature	Position	Protein similarity/EST matches
C15	C/2504-3864	
W30	W/8619-9131	hypothetical protein F30H5.2, <i>Caenorhabditis elegans</i> , 1.6e-05
W50	W/12306-12944	glycine-rich protein GRP22, rape, PIR:S31415, 1.6e-36
C75	C/16037-17967	PREG like protein, <i>Arabidopsis thaliana</i> , EMBL:AB012239, 5.2e-38
C90	C/20929-24200	DNA-binding protein ABF1—wild oat, PIR:S61413, 5.0e-28
C110	C/30589-31850	
C135	C/38132-41466	predicted protein, <i>Arabidopsis thaliana</i> , PIR:T49221, 8.7e-133/D25127
C180	C/47976-49075	predicted protein, <i>Oryza sativa</i> , EMBL:AC026815, 1.9e-23
C200	C/50060-56958	27k vesicle-associated membrane protein-associated protein (VAMP), curled-leaved tobacco, EMBL:AB018117, 4.8e-84
C202	C/58901-61517	plastid ribosomal protein L19 precursor, <i>Spinacia oleracea</i> , EMBL:AF250384, 5.3e-59,/C74047
W230	W/62697-64415	extensin-like protein—maize, PIR:S49915, 1.2e-06,/AU030763, AU070696, AU030762
tRNA	C/64886-65017	tRNA predict as a tRNA- Arg : anticodon acg
tRNA	C/64886-64957	tRNA predict as a tRNA- Pro : anticodon ggg
W265	W/65017-67265	cAMP inducible 2 protein, <i>Mus musculus</i> , EMBL:AF121081, 1.5e-123
C285	C/70640-71035	
transposon	C/77159-80730	transposon
W325	W/83990-84706	glycine-rich protein 2, <i>Arabidopsis thaliana</i> , PIR:T05494, 7.5e-09
C345	C/85408-87116	uclacyanin 3, <i>Arabidopsis thaliana</i> , PIR:T49223, 3.3e-36/BE040770, BE040904, AU071152, AU071239, AU070738, AU071112, AU071195, AU070659, AU070774, AU071224, AU095618, AU163454, AU071095, AU070835, AU071193, AU070840, C25085
W380	W/90519-91174	
C395	C/91818-95108	predicted protein, <i>Arabidopsis thaliana</i> , PIR:T48310, 3.7e-28
W420	W/96931-97865	
W435	W/100319-102879	predicted protein, <i>Oryza sativa</i> , EMBL:AB026295, 8.5e-12
C440	C/104495-104992	
W455	W/106602-110890	GTP-binding protein—maize, PIR:B38202, 2.7e-136/BE039980, AU092678, AU092609, AU092889, AU030259, AU064907, AU064033, D49344, C93488, D2387, C25096, AU066159, AU066160, AU030258, C28045, C25059, C27780, D22939, AU057614, C28341
W485	W/120269-121903	probable triacylglycerol lipase, <i>Arabidopsis thaliana</i> , PIR:E71435, 2.3e-110/AU101257, AU064146, AU064563, AU064925, AU065141, AU065117, AU094966
W495	W/122503-126090	probable enoyl-CoA hydratase, <i>Arabidopsis thaliana</i> , PIR:C71435, 4.6e-60
W505	W/126711-129864	probable enoyl-CoA hydratase, <i>Arabidopsis thaliana</i> , PIR:C71435, 5.7e-64
W535	W/134248-136831	protein kinase (EC 2.7.1.37) 5, <i>Arabidopsis thaliana</i> , PIR:JN0505, 4.8e-138
C555	C/137352-143243	predicted protein, <i>Arabidopsis thaliana</i> , EMBL:AB008267, 3.1e-81
W595	W/145530-149814	ubiquitin thiolesterase (EC 3.1.2.15) L3, human, PIR:A40085, 3.3e-52/AU058175, C25250
C600	C/150409-152412	bZIP protein, <i>Arabidopsis thaliana</i> , PIR:T49227, 5.4e-73,/AU163243
C635	C/159754-160665	CDBP <i>Mesembryanthemum crystallinum</i> AP2-related transcription factor, EMBL:AF245119, 7.9e-51/ AU057740, AU083516
C650	W/164858-168510	predicted protein, <i>Arabidopsis thaliana</i> , PIR:T00408, 2.0e-77
W700	W/180768-181805	ethylene responsive element binding factor 5, <i>Arabidopsis thaliana</i> , PIR:T52020, 1.1e-35
C740	C/192640-193413	3-isopropylmalate dehydratase-like protein (small subunit), <i>Arabidopsis thaliana</i> , PIR:T47781, 4.5e-64 /AU172969, AU163547, AU096007, AU096006, D22329, AU101178, AU162746, AU094753, AU101179
W760	W/195850-197387	predicted protein, <i>Arabidopsis thaliana</i> , 1.8e-10
C780	C/200773-205219	predicted protein, <i>Arabidopsis thaliana</i> , EMBL:AB023044
C785	C/209473-210472	
W815	W/211666-217666	predicted protein, <i>Arabidopsis thaliana</i> , EMBL:AC024174, 1.6e-244
C825	C/219153-221701	kinase-like transmembrane protein TMKL1 precursor, <i>Arabidopsis thaliana</i> , PIR:S39476, 1.8e-49,/ AU056887
W855	W/224272-224625	
C870	C/225607-226540	predicted protein, <i>Arabidopsis thaliana</i> , EMBL:ATH288958, 9.9e-13
C875	C/228468-234134	predicted protein, <i>Arabidopsis thaliana</i> , EMBL:AB023044, 1.5e-98
W920	W/235513-239385	CDC23, human, EMBL:AB011472, 7.0e-138,/C28583
W930	W/244097-247111	LDJ2 (DnaJ) protein, leek, PIR:S42031, 8.0e-226/AU031322, C26206, AU030551, AU092294, AU101483, C28691, AU031323, AU070856, AU070832, D38865, D38877
W940	W/248749-249612	transcription factor TINY, <i>Arabidopsis thaliana</i> , PIR:T01076, 7.4e-39
W950	W/249771-250715	probable tonoplast aquaporin—maize, PIR:T01648, 9.7e-117/D23748, AU173162, AU163445, AU083016, D24190, D24763, AU031632, AU065449, AU173163, D24895
Retrotransposon	W/256930-263084	Ty3/Gypsy-like retrotransposon
C1015	C/263711-266955	predicted protein, <i>Oryza sativa</i> , EMBL:AP000399, 0.0
W1050	W/270285-271770	hypothetical protein, <i>Arabidopsis thaliana</i> , PIR:G71442, 1.7e-80
C1075	C/272186-272851	predicted protein, <i>Oryza sativa</i> , EMBL:AC051633, 3.5e-23
W1110	W/280506-283120	predicted protein, <i>Arabidopsis thaliana</i> , PIR:T05538, 8.3e-24/BE230101, BE230297
C1125	C/284043-285083	acetylglutamate kinase-like protein, <i>Arabidopsis thaliana</i> , PIR:T46192, 8.0e-113
C1145	C/286907-288305	
C1190	C/305291-305968	AP2 domain transcription factor, <i>Arabidopsis thaliana</i> , EMBL:AC006068, 1.9e-40
W1205	W/310298-310597	predicted protein, <i>Oryza sativa</i> , EMBL:AP002094, 8.3e-37
C1225	C/312769-313464	fibroin-2, <i>Araneus diadematus</i> , EMBL:AD47854, 1.5e-13
W1245	W/322960-323955	
C1265	C/331539-332006	transcription factor TINY— <i>Arabidopsis thaliana</i> , PIR:T01076, 6.4e-17
C1275	C/332068-332877	tonoplast intrinsic protein 1 (TIP1), <i>Hordeum vulgare</i> , EMBL:AF254799, 4.9e-90/AU173162, D23748, AU163445, AU083016, D24190, D24763, AU065449, D24895

Table 2. Functional Domains of Predicted Rice Proteins

Predicted gene	Interpro domains	
C15	IPR000104	Type I antifreeze protein
W50	IPR001687	ATP/GTP-binding site motif A (P-loop)
	IPR000817	Prion protein
	IPR002952	Eggshell protein
C90	IPR001472	Bipartite nuclear localization signal
	IPR000104	Type I antifreeze protein
C200	IPR000535	Major sperm protein (MSP) domain
C202	IPR001857	Ribosomal protein L19
W230	IPR002965	Proline rich extensin
W265	IPR000694	Proline-rich region
W325	IPR001878	Zn-finger CCHC type
C345	IPR002965	Proline rich extensin
	IPR001402	Probable G protein-coupled receptor GPR10
W455	IPR001687	ATP/GTP-binding site motif A (P-loop)
	IPR002078	Sigma-54 factor interaction protein family
	IPR001806	Ras family
W485	IPR000734	Lipase
W495	IPR001753	Enoyl-CoA hydratase/isomerase
W505	IPR001753	Enoyl-CoA hydratase/isomerase
W535	IPR002290	Serine/Threonine protein kinases active-site
	IPR000379	Esterase/lipase/thioesterase active site
	IPR000719	Eukaryotic protein kinase
W595	IPR001578	Ubiquitin carboxyl-terminal hydrolases family 1
	IPR000694	Proline-rich region
C600	IPR000694	Proline-rich region
C635	IPR001471	AP2 domain/ethylene responsive element binding protein
	IPR000104	Type I antifreeze protein
W700	IPR001471	AP2 domain/ethylene responsive element binding protein
W760	IPR002293	Permease for amino acids and related compounds, family 1
C780	IPR000379	Esterase/lipase/thioesterase active site
W815	IPR001865	Ribosomal protein S2
C825	IPR001245	Tyrosine kinase catalytic domain
C875	IPR001472	Bipartite nuclear localization signal
	IPR000719	Eukaryotic protein kinase
W920	IPR001440	TPR repeat
W930	IPR001623	DnaJ N-terminal domain
	IPR001305	DnaJ central domain (CXXCXGXG)
	IPR003095	DNAJ heat shock protein
	IPR001472	Bipartite nuclear localization signal
W940	IPR001778	Pollen allergen Poa pl signature
	IPR001471	AP2 domain/ethylene responsive element binding protein
	IPR000104	Type I antifreeze protein
W950	IPR001472	Bipartite nuclear localization signal
	IPR000425	MIP family
W1050	IPR001778	Pollen allergen Poa pl signature
W1110	IPR000173	Glyceraldehyde 3-phosphate dehydrogenase
C1125	IPR001472	Bipartite nuclear localization signal
	IPR001057	Glutamate 5-kinase
C1145	IPR001472	Bipartite nuclear localization signal
C1190	IPR001471	AP2 domain/ethylene responsive element binding protein
	IPR000104	Type I antifreeze protein
C1225	IPR002086	Aldehyde dehydrogenase family

Analysis of Additional Regions of the Rice Genome

To assess the generality of our findings of gene density in the rice genome and the conservation of microstructure with the genome of *Arabidopsis*, we selected for analysis two further BACs that had been sequenced and submitted to public databases. One of these, P0436E04 (accession no. ap002818), was selected as the sequenced clone nearest to a telomere (map position 0.3 cM on chromosome 1). The other, P0406H10 (accession no. ap002524), was near the middle of a chromosome arm (20.2 cM on chromosome 1). We implemented our annotation protocols using these data and compared the putative genes derived with those accompanying the database

submission. For P0436E04, 26 genes and three transposons were identified in 145 kb of sequence, compared with 24 genes and two transposons recorded with the submission. For P0406H10, 25 genes and one transposon were identified in 156 kb of sequence, compared with 26 genes and one transposon recorded with the submission. The densities of putative genes identified, one per 5.6 kb and one per 6.2 kb for P0436E04 and P0406H10, respectively, are very similar to the density found in the 340-kb region analyzed (one per 6.1 kb). Although the annotation accompanying database submissions of rice genome sequence suggested significantly different gene structures to those predicted by our protocols, the overall gene density predicted is very similar. The gene densities of these clones are typical of those accompanying the rice BAC sequences presently in the public databases. These results suggest that a typical gene density for the rice genome is around one gene per 6 kb.

Searches were conducted for segments of the *Arabidopsis* genome that contain conserved gene content and order for each of BAC clones P0436E04 and P0406H10. The same methods and recording criteria were used. The results are summarized in Table 4 and Figure 4 for P0406H10, and Table 5 and Figure 5 for P0436E04. In both cases multiple conserved segments were identified. Only three or four conserved genes were identified in each segment; there was one reversal of gene order (W1600-AT5g07380 and W3350-AT5g07690), and the strand orientation of several of the genes was not conserved (i.e., C3852-AT1g80360, C2000-AT4g32610, W399-AT5g63880, C3900-AT5g07080). However, these results indicate that it may be feasible to

align much of the rice genome with duplicated segments of the genome of *Arabidopsis*.

DISCUSSION

Using a combination of approaches, 56 genes were predicted in the 340 kb of rice genome sequence data we generated and analyzed, indicating a density of one gene per 6.1 kb. This density is close to that found for the genome of *Arabidopsis*; that is, one gene per 4.76 kb (Bancroft 2000), but higher than that found near the *ADH1* locus of rice, one gene per 10.3 kb (Tarchini et al. 2000). Extrapolation to the 440-Mb genome of rice, using the gene densities of one per 6.1 kb or 10.3 kb,

Table 3. Homology Scores for Conserved *Arabidopsis* and Rice Genes: Rice Chromosome 2 Segment

Rice gene	<i>Arabidopsis</i> genes (P value)
C75	AT2g44740 (8.1e-37) C
C135	AT2g44780 (1.2e-83) C; AT3g60260 (1.5e-83) W
C200	AT5g47180 (4.3e-54) C
C202	AT4g17560 (1.0e-22) W; AT5g47190 (2.3e-39) C
W265	AT4g17550 (2.1e-143) C
C345	AT3g60270 (1.1e-25) C
W455	AT4g17530 (6.0e-96) C; AT5g47200 (1.1e-71) W
W485	AT2g44810 (3.7e-70) W; AT4g16820 (1.3e-105) W
W495	AT4g16800 (3.7e-54) C
W505	AT4g16800 (2.0e-58) C
W535	AT2g44830 (1.4e-170) W
W595	AT4g17510 (3.8e-71) C
C600	AT3g60320 (9.6e-74) C
C635	AT4g17500 (6.6e-35) W; AT5g47220 (4.7e-31) C; AT2g44840 (4.1e-30) W
C650	AT2g44850 (8.9e-63) W
W700	AT4g17490 (3.1e-21) C; AT5g47230 (9.2e-27) W
W760	AT4g17486 (2.7e-44) C; AT5g47310 (1.1e-50) W
C870	AT4g16790 (5.5e-7) C; AT3g60380 (4.4e-9) C
W940	AT3g44940 (1.7e-36) C; AT4g16750 (1.3e-31) C
W950	AT4g17340 (6.7e-97) W; AT5g47450 (4.1e-97) C
W1050	AT4g17350 (8.0e-46) W; AT5g47440 (1.8e-46) C; AT4g16670 (1.3e-36) W
C1190	AT2g44940 (1.6e-31) C; AT3g60490 (3.7e-31) W

would predict the presence of ~72,000 or ~43,000 genes in the rice genome, respectively. However, there is evidence of gene-rich and gene-poor isochores in the rice genome based on bulk sequence composition (Barakat et al. 1997), and both regions analyzed are likely to be characteristic of the gene-rich regions. If we estimate that the rice ESTs presently in dbEST represent ~10,000 nonredundant genes, our observation that 16 of the 56 predicted genes identified (29%) have EST matches leads us to predict a total gene number for rice of ~35,000. This would be consistent with a model in which the majority of the rice genes are contained in gene-rich regions comprising 50% of the genomic DNA of rice (220 Mb), with these gene-rich regions typically containing a gene density of one per ~6 kb, as we have observed.

The composition of the region we have analyzed differs significantly from that near the *ADH1* locus (Tarchini et al. 2000). In addition to more predicted genes in a region of almost identical size (56, compared with 33), we identified fewer transposons and retrotransposons (2, compared with 15). There are smaller gene/pseudogene families; for example, the largest gene family we identified contained four members, compared to 13 members. The region around the *ADH1* locus contains several genes with homology to genes known to be involved in plant disease resistance. It has a complex structure, including a large family of genes, some of which do not encode a full and functional protein, and several retrotransposons. This resembles the structure of the *Arabidopsis* ecotype Columbia allele of the RPP5 disease-resistance locus identified on chromosome 4 (Bevan et al. 1998). However, this is an unusual genome organization, and is not representative of the genome structure as a whole (Lin et al. 1999; Mayer et al. 1999).

Sixteen of the 56 modeled genes (29%) match EST sequences, supporting the predicted gene models. Further support for the authenticity of our predicted genes come from the

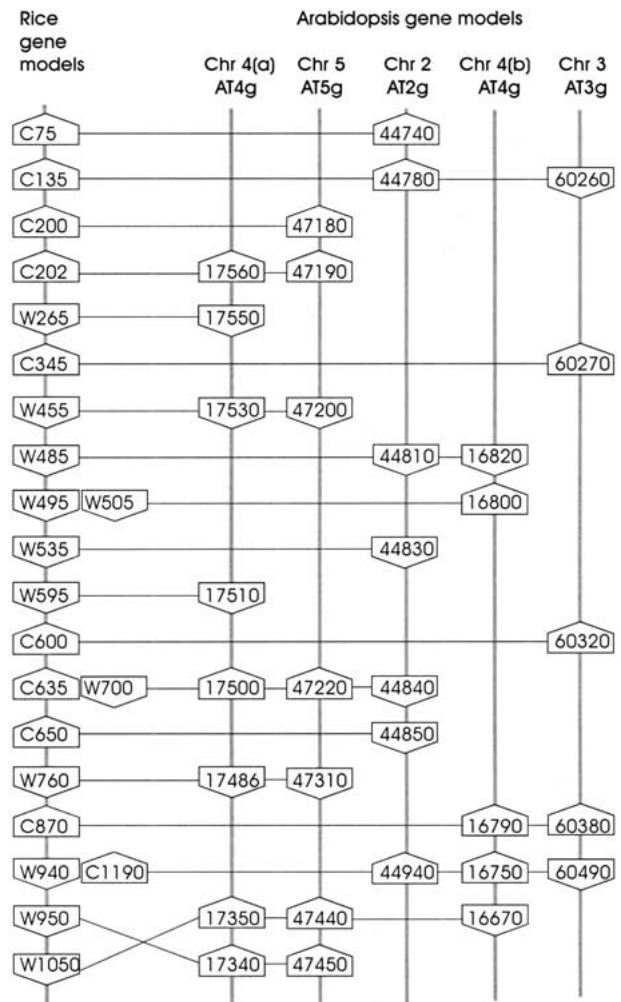
**Figure 3** Comparison of the organization of conserved putative genes in the 333-kb rice DNA sequence and five segments of the *Arabidopsis* genome sequence. The relative coding strands of the genes are indicated by up- or down-pointing polygons. Duplicated genes in the rice sequence that detected homology to common *Arabidopsis* genes are indicated next to each other at the position of the gene with the lower reference number.

highly significant homology that the predicted products of many of them show to known or predicted proteins in other species. Forty-six of the 56 predicted genes (82%) show such homology. These data suggest that the majority of our gene

Table 4. Homology Scores for Conserved *Arabidopsis* and Rice Genes: BAC P0406H10

Rice gene	<i>Arabidopsis</i> genes (P value)
W750	AT3g24480 (1.5e-106) C
W1200	AT3g24460 (2.9e-32) C
C1700	AT4g32620 (8.1e-100) W
C1702	AT1g80810 (8.1e-08) W; AT4g32620 (3.7e-32) W
C2000	AT4g32610 (4.1e-09) C
C2002	AT3g24350 (4.8e-94) W
C2702	AT1g80400 (3.7e-96) W; AT4g32600 (8.9e-102) W
W3300	AT1g80390 (7.7e-24) C
C3852	AT1g80360 (7.3e-68) C

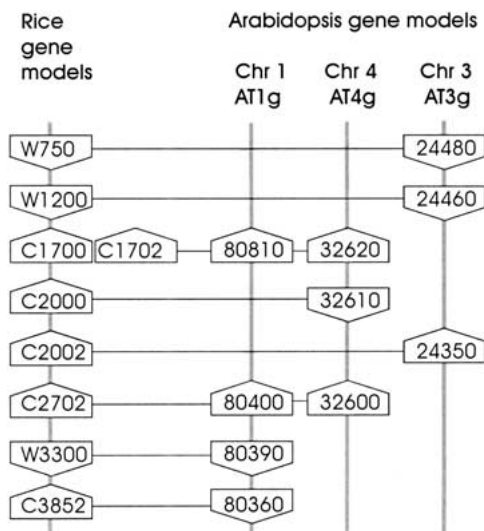

Figure 4 Comparison of the organization of conserved putative genes in rice BAC P0406H10 and three segments of the *Arabidopsis* genome sequence. Representation is as shown in Figure 3.

models correctly indicate the presence of a gene. It also suggests that the EST representation in rice may be relatively low, which in turn might indicate that many of the genes of rice are expressed at low levels generally, only in specific cells or in response to specific conditions. The 10 gene models for which no homology has been identified may be false gene predictions or genes unique to rice.

The framework of conserved genes preserved between segments of the genomes of *Arabidopsis* and rice suggests that mechanisms of genome evolution have been operating to delete, rearrange, and disperse single or small groups of genes, resulting in extensive genome reshuffling during plant evolution. This is inconsistent with the suggestion that plant genome organization might have evolved primarily by gross rearrangements, permitting the construction of unified genetic maps (Paterson et al. 1996). Mechanisms that might achieve the observed divergence of genome fine structure may involve mobile genetic elements, as has been found to contribute to "exon shuffling" in mammalian systems (Boeke and Pickeral 1999). It is also likely that unequal crossing over contributes to both tandem duplications of genes, and deletion of single or small groups of genes (Bancroft 2001).

Many duplicated regions have been identified within the genome of *Arabidopsis* (Lin et al. 1999; Mayer et al. 1999; Bancroft 2000). It has been suggested that these may have been the result of an ancestral tetraploidy event (Blanc et al. 2000; The *Arabidopsis* Genome Initiative 2000), or multiple duplication events (Vision et al. 2000). Our data support the

Table 5. Homology Scores for Conserved *Arabidopsis* and Rice Genes: BAC P0436E04

Rice gene	<i>Arabidopsis</i> genes (<i>P</i> value)
W399	AT5g63880 (5.5e-08) W
W1600	AT5g07380 (8.5e-55) W
W2200	AT5g63790 (5.3e-53) C
W3350	AT5g07680 (1.9e-60) W
C3900	AT5g63560 (1.4e-46) W; ATg07080 (1.2e-30) W
C4600	AT5g63560 (1.7e-08) W; AT5g07080 (2.1e-06) W

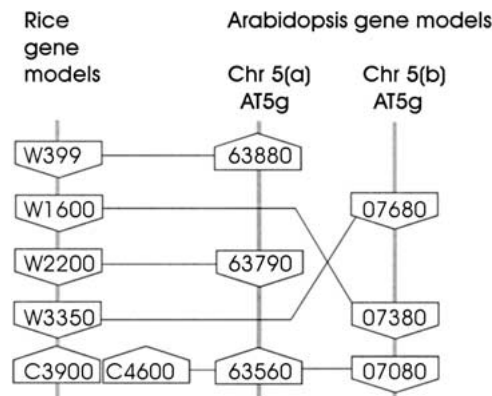

Figure 5 Comparison of the organization of conserved putative genes in rice BAC P0436E04 and two segments of the *Arabidopsis* genome sequence. Representation is as shown in Figure 3.

hypothesis that there have been multiple duplication events during the evolution of the genome of *Arabidopsis*. These duplicated segments appear to have diverged extensively by the loss of different subsets of interspersed genes. The relationships of such highly diverged duplicated segments is revealed most clearly by comparative sequence analysis with relatively distantly related species, such as tomato (Ku et al. 2000) or rice. By integrating the data from multiple duplicated segments of the *Arabidopsis* genome we have been able to align segments of the rice and *Arabidopsis* genomes and deduce the ancestral relationships of sets of genes. It is not known whether the 340-kb rice genome segment studied is also the product of genome duplication events during the ancestry of rice. When the rice genome sequence data become available, it should be possible to analyze complex relationships within the rice genome by extensive analysis using the *Arabidopsis* genome sequence. By taking due account of the mechanisms of the evolution of plant genome structure, it may be possible to make extensive use of comparative genome analysis to integrate structural and functional genomics of dicot and monocot species.

METHODS

Sequencing of BAC Clones

Individual BAC clones were sequenced by standard methods using a shot-gun approach (Bodenteich et al. 1993). Cesium chloride-purified BAC DNA was sheared by nebulization (Roe et al. 1996). After end-filling, DNA fragments were size fractionated and cloned into the *Sma*I site of pUC18 or *Hinc*II site of pUC19 (Amersham Pharmacia Biotech). Clones were sequenced using the ABI PRISM Dye Terminator Cycle Sequencing ready Reaction kit with FS AmpliTaq DNA polymerase (PE Applied Biosystems) and analyzed on ABI 377 (PE Applied Biosystems) sequencing gels. The sequence data were assembled using PHRED/PHRAP software (Green 1996).

Analysis of Sequence Data

The sequence was subjected to a modified analysis procedure based on that established for genome analysis of *Arabidopsis thaliana* (Mayer et al. 1999). BLAST (Altschul et al. 1997) analysis of the sequence against the EMBL nucleotide database and MIPS in-house databases (a nonredundant protein database, a plant transposon database, a rice EST database, and an all-plant EST database) was performed. Gene predictions were performed using Genscan (Burge and Karlin 1997), GeneFinder (P. Green and L. Hillier, unpubl. software),

FGENESH (A.A. Salamov and V.V. Soloyev, unpubl. software; <http://genomic.sanger.ac.uk/gf/gf.shtml>), and Genemark.hmm (Lukashin and Borodovsky 1998). An *Oryza sativa* setting is available only for Genemark.hmm. For GeneFinder as well as Genscan the *Arabidopsis* setting was used. The *Zea mays* setting available for Genscan yielded less reliable results. Splice-site predictions using Netplantgene2 (Tolstrup et al. 1997) (*Arabidopsis* setting) gave unreliable results, and was not used for gene modeling.

Gene modeling was performed by combining intrinsic data (gene predictions) with extrinsic data (database matches). Gene models were adjusted to fit EST data from rice and other plants as well as to homologous protein matches where available. For genes not supported by any database matches the FGENESH prediction was generally used.

Protein domain characterization was performed using the InterPro software (The InterPro Consortium 2000), and similarity analysis of extracted proteins was performed by BLASTP comparison to a nonredundant protein database.

ACKNOWLEDGMENTS

This work was funded under the BBSRC GAIT Initiative (grant 208/GAT09069) and the EU *Arabidopsis* Genome Sequencing Project (CT97-0274).

The publication costs of this article were defrayed in part by payment of page charges. This article must therefore be hereby marked "advertisement" in accordance with 18 USC section 1734 solely to indicate this fact.

REFERENCES

- Arumuganathan, K. and Earle, E.D. 1991. Nuclear DNA content of some important plant species. *Plant Mol. Biol. Rep.* **9**: 208–218.
- Altschul, S.F., et al. 1997. Gapped BLAST and PSI-BLAST: A new generation of protein database search programs. *Nucleic Acids Res.* **25**: 3389–3402.
- Bancroft, I. 2000. Insights into the structural and functional evolution of plant genomes afforded by the nucleotide sequences of chromosomes 2 and 4 of *Arabidopsis thaliana*. *Yeast* **17**: 1–5.
- . 2001. Duplicate and diverge: The evolution of plant genome microstructure. *Trends Genet.* **17**: 89–93.
- Bancroft, I., Jones, J.D.G., and Dean, C. 1993. Heterologous transposon tagging of the *DRL1* locus in *Arabidopsis*. *Plant Cell* **5**: 631–638.
- Barakat, A., Carels, N., and Bernardi, G. 1997. The distribution of genes in the genomes of Gramineae. *Proc. Natl. Acad. Sci.* **94**: 6857–6861.
- Bevan, M., et al. 1998. Analysis of 1.9 Mb of contiguous sequence from chromosome 4 of *Arabidopsis thaliana*. *Nature* **391**: 485–488.
- Blanc, G., Barakat, A., Guyot, R., Cooke, R., and Delseny, M. 2000. Extensive duplication and reshuffling in the *Arabidopsis* genome. *Plant Cell* **12**: 1093–1101.
- Bodenteich, A., Chissoe, S., Wang, Y.F., and Roe, B.A. 1993. Shot-gun cloning as the strategy of choice to generate templates for high-throughput dideoxynucleotide sequencing. In *Automated DNA sequencing and analysis techniques* (ed. J.C. Venter), pp. 42–50. Academic Press, London.
- Boeke, J.D. and Pickeral, O.K. 1999. Retroshuffling the genomic deck. *Nature* **398**: 108–111.
- Burge, C. and Karlin, S. 1997. Prediction of complete gene structures in human genomic DNA. *J. Mol. Biol.* **268**: 78–94.
- Cavell, A.C., Lydiate, D.J., Parkin, I.A.P., Dean, C., and Trick, M. 1998. Collinearity between a 30-centimorgan segment of *Arabidopsis thaliana* chromosome 4 and duplicated regions within the *Brassica napus* genome. *Genome* **41**: 62–69.
- Chen, M., SanMiguel, P., and Bennetzen, J.L. 1998. Sequence organization and conservation in sh2/a1-homologous regions of sorghum and rice. *Genetics* **148**: 435–443.
- Devos, K.M., Beales, J., Nagamura, Y., and Sasaki, T. 1999. *Arabidopsis*-rice: Will colinearity allow gene prediction across the eudicot-monocot divide? *Genome Res.* **9**: 825–829.
- Feldmann, K.A., Marks, M.D., Christianson, M.L., and Quatrano, R.S. 1989. A dwarf mutant of *Arabidopsis* generated by T-DNA insertional mutagenesis. *Science* **243**: 1351–1354.
- Gale, M.D. and Devos, K.M. 1998. Plant comparative genetics. *Science* **282**: 656–659.
- Giraudat, J., Hauge, B.M., Valon, C., Smalle, J., Parcy, F., and Goodman, H.M. 1992. Isolation of the *Arabidopsis* ABI3 gene by positional cloning. *Plant Cell* **4**: 1251–1261.
- Green, P. 1996. Towards completely automated sequence assembly. DOE Human Genome Program Contractor-Grantee Workshop V, 157, U.S. Department of Energy, Office of Science, Office of Biological and Environmental Research, Washington, DC.
- Han, F., Kilian, A., Chen, J.P., Kudrna, D., Steffenson, B., Yamamoto, K., Matsumoto, T., Sasaki, T., and Kleinjohs, A. 1999. Sequence analysis of a rice BAC covering the syntenous barley *Rpg1* region. *Genome* **42**: 1071–1076.
- Kinoshita, T. 1995. Report of committee on gene symbolization. *Rice Genet. Newsl.* **12**: 9–153.
- Koornneef, M. 1990. *Arabidopsis thaliana*. In *Genetic maps* (ed. S. J. O'Brien), pp. 6.93–9.96. Cold Spring Harbor Laboratory Press, New York.
- Kowalski, S.P., Lan, T.-H., Feldmann, K.A., and Paterson, A.H. 1994. Comparative mapping of *Arabidopsis thaliana* and *Brassica oleracea* chromosomes reveals islands of conserved organization. *Genetics* **138**: 499–510.
- Ku, H.-M., Vision, T., Liu, S., and Tanksley, S.D. 2000. Comparing sequenced segments of the tomato and *Arabidopsis* genomes: Large-scale duplication followed by selective gene loss creates a network of synteny. *Proc. Natl. Acad. Sci.* **97**: 9121–9126.
- Kurata, N., et al. 1994. A 300 kilobase interval genetic map of rice including 883 expressed sequences. *Nat. Genet.* **8**: 365–372.
- Lagercrantz, U. 1998. Comparative mapping between *Arabidopsis thaliana* and *Brassica napus* indicates that brassica genomes have evolved through extensive genome replication accompanied by chromosome fusion and frequent rearrangements. *Genetics* **150**: 1217–1228.
- Lin, X., et al. 1999. Sequence and analysis of chromosome 2 of the plant *Arabidopsis thaliana*. *Nature* **402**: 761–768.
- Lister, C. and Dean, C. 1993. Recombinant inbred lines for mapping RFLP and phenotypic markers in *Arabidopsis thaliana*. *Plant J.* **4**: 745–750.
- Lukashin, A.V. and Borodovsky, M. 1998. GeneMark.hmm: New solutions for genefinding. *Nucleic Acids Res.* **26**: 1107–1115.
- Mayer, K., et al. 1999. Sequence and analysis of chromosome 4 of the plant *Arabidopsis thaliana*. *Nature* **402**: 769–777.
- Moore, G., Devos, K.M., Wang, Z., and Gale, M.D. 1995. Grasses, line up and form a circle. *Curr. Biol.* **5**: 737–739.
- Paterson, A.H., et al. 1996. Towards a unified genetic map of higher plants, transcending the monocot-dicot divergence. *Nat. Genet.* **14**: 380–382.
- Roe, B.A., Crabtree, J.S., and Khan, A.S. 1996. *DNA isolation and sequencing*. John Wiley and Sons, New York.
- Schmidt, R., West, J., Love, K., Lenehan, Z., Lister, C., Thompson, H., Bouchez, D., and Dean, C. 1995. Physical map and organization of *Arabidopsis thaliana* chromosome 4. *Science* **270**: 480–483.
- Tarchini, R., Biddle, P., Wineland, R., Tingey, S., and Rafalski, A. 2000. The complete sequence of 340 kb of DNA around the rice *Adh1-Adh2* region reveals interrupted colinearity with maize chromosome 4. *Plant Cell* **12**: 381–391.
- The *Arabidopsis* Genome Initiative. 2000. Analysis of the genome sequence of the flowering plant *Arabidopsis thaliana*. *Nature* **408**: 796–815.
- The InterPro Consortium. 2000. InterPro—An integrated documentation resource for protein families, domains and functional sites. *Bioinformatics* **16**: 1145–1150.
- Tikhonov, A.P., SanMiguel, P.J., Nakajima, Y., Gorenstein, N.M., Bennetzen, J.L., and Avramov, Z. 1999. Colinearity and its exceptions in orthologous adh regions of maize and sorghum. *Proc. Natl. Acad. Sci.* **97**: 7409–7414.
- Tolstrup, N., Rouze, P., and Brunak, S. 1997. A branch point consensus from *Arabidopsis* found by non-circular analysis allows for better prediction of acceptor sites. *Nucleic Acids Res.* **25**: 3159–3163.
- van Dodeweerd, A.-M., Hall, C.R., Bent, E.G., Johnson, S.J., Bevan, M.W., and Bancroft, I. 1999. Identification and analysis of homoeologous segments of the genomes of rice and *Arabidopsis thaliana*. *Genome* **42**: 887–892.
- Vision, T.J., Brown, D.G., and Tanksley, S.D. 2000. The origins of genomic duplications in *Arabidopsis*. *Science* **290**: 2114–2117.
- Wolfe, K.H., Gouy, M., Yang, Y.-W., Sharp, P.M., and Li, W.-H. 1989. Date of the monocot-dicot divergence estimated from chloroplast DNA sequence data. *Proc. Natl. Acad. Sci.* **86**: 6201–6205.

Received August 23, 2000; accepted in revised form April 3, 2001.