



Identification of New X-Chromosomal Genes Required for *Drosophila* Oogenesis and Novel Roles for *fs(1)Yb*, *brainiac* and *dunce*

Andrew Swan, Sirine Hijal, Andres Hilfiker, et al.

Genome Res. 2001 11: 67-77

Access the most recent version at doi:[10.1101/gr.156001](https://doi.org/10.1101/gr.156001)

References

This article cites 39 articles, 31 of which can be accessed free at:
<http://genome.cshlp.org/content/11/1/67.full.html#ref-list-1>

License

Email Alerting Service

Receive free email alerts when new articles cite this article - sign up in the box at the top right corner of the article or [click here](#).

A promotional banner for Cellecta's CRISPR and RNAi Genetic Screening services. The text reads "CRISPR and RNAi Genetic Screening. Your new superpower." and includes a "LEARN MORE" button. The background features a woman in a red superhero mask and cape, and the Cellecta logo.

To subscribe to *Genome Research* go to:
<https://genome.cshlp.org/subscriptions>

Cold Spring Harbor Laboratory Press

Identification of New X-Chromosomal Genes Required for *Drosophila* Oogenesis and Novel Roles for *fs(1)Yb*, *brainiac* and *dunce*

Andrew Swan,¹ Sirine Hijal, Andres Hilfiker,² and Beat Suter³

Department of Biology, McGill University, Montreal, Quebec H3A 1B1, Canada

We performed a screen for female sterile mutations on the X chromosome of *Drosophila melanogaster* and identified new loci required for developmental events in oogenesis as well as new alleles of previously described genes. We present mapping and phenotypic characterization data for many of these genes and discuss their significance in understanding fundamental developmental and cell biological processes. Our screen has identified genes that are involved in cell cycle control, intracellular transport, cell migration, maintenance of cell membranes, epithelial monolayer integrity and cell survival or apoptosis. We also describe new roles for the genes *dunce* (*dnc*), *brainiac* (*bm*) and *fs(1)Yb*, and we identify new alleles of *Sex lethal* (*Sxl*), *ovarian tumor* (*otu*), *sans filles* (*snf*), *fs(1)K10*, *singed* (*sn*), and *defective chorion-1* (*dec-1*).

Oogenesis in *Drosophila* has become one of the best characterized model systems for studying basic questions in developmental and cell biology. The fly ovary consists of a relatively small number of cell types, yet these cells are involved in a number of complex processes such as cell–cell signaling, cell migration, asymmetric division, intracellular transport, and nuclear migration. A full range of genetic, molecular, and cell biological techniques have been developed for studying *Drosophila* oogenesis, making it an ideal model system. It is predicted that over 70% of all loci in *Drosophila* play an essential role in the female germline (Perrimon et al. 1996), meaning that the majority of *Drosophila* genes can be studied in this relatively simple system.

Drosophila has long been a strong model for studying genes in a developmental system. With the completion of the *Drosophila* genome sequencing (Adams et al. 2000), there has also been a tremendous growth of interest in elucidating the function of newly discovered genes, in particular the ones with interesting human homologs. Of the model genomes which have been sequenced, the *Drosophila* genome has the highest similarity with the human one. A high percentage of *Drosophila* genes have clear orthologs in human, and 61% of human disease and 68% of human cancer genes have direct orthologs in *Drosophila* (Rubin et al. 2000).

Genetic screens for mutations that specifically affect female fertility have identified a large number of

genes that function in the ovary (Gans et al. 1975; Mohler 1977; Schupbach and Wieschaus 1991). A subset of these genes is only essential for oogenesis. Since any mutation that disrupts such a gene will lead to female sterility, multiple alleles have typically been found for these genes. The other major class of genes that has been identified is represented by single alleles, and it is thought that these alleles largely represent genes that are not only required for oogenesis but are also essential for viability. Specific alleles of essential genes can result in female sterility either because the mutation specifically disrupts function of the gene during oogenesis or because hypomorphic alleles may provide enough gene function for other processes but not enough for oogenesis. In previous screens, more than half of all female sterile loci identified represented novel, presumably essential loci (Perrimon et al. 1986). We have carried out a new screen of the X chromosome and have identified new alleles of several known X chromosome female sterile loci as well as alleles of novel genes required for *Drosophila* oogenesis.

RESULTS AND DISCUSSION

Overview of *Drosophila* Oogenesis

The *Drosophila* ovary consists of approximately 15 ovarioles, each of which acts as an assembly line in egg production (Fig. 1; for a review of oogenesis, see Spradling 1993). At the anterior of the ovariole, in the germarium, the germline and somatic cells of the ovary come together to make up the basic unit of oogenesis, the egg chamber. The germarium is divided into three regions. In region one, at the anterior tip of the germarium, two or three stem cells reside. These cells undergo an asymmetric division to produce a daughter stem cell and a cystoblast. The cystoblast then under-

¹Present addresses: Dept. of Molecular Biology, Princeton University, Princeton, NJ 08544, USA; ²Dept. of Cardiology, Medizinische Hochschule Hannover, D-30625, Germany.

³Corresponding author.

E-MAIL Beat_Suter@maclean.mcgill.ca; FAX (514) 398 8051.

Article and publication are at www.genome.org/cgi/doi/10.1101/gr.156001.

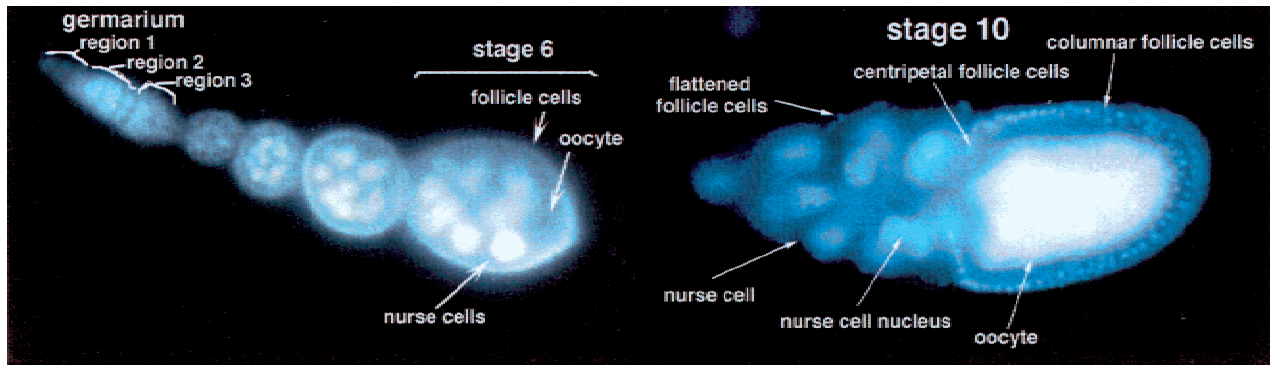

Figure 1 Oogenesis in wild type *Drosophila*. A gerarium with the three different germarial regions (indicated) is shown and a vitellarium with stages 2–6, and a stage 10 egg chamber.

goes four rounds of mitosis, each with incomplete cytokinesis, producing a cyst of 16 cells connected by cytoplasmic bridges called ring canals. Two of these cells will possess four ring canals, and one of these two cells will differentiate into the oocyte. The other 15 cells adopt a nurse cell fate and serve mainly to produce and transport into the oocyte materials required by the oocyte for growth and patterning. At the end of region 2a of the gerarium, approximately 15 somatic follicle cells begin to surround the 16-cell cyst, and in region 2b, these cells have completely surrounded the cyst. In region 3 of the gerarium, also referred to as stage 1 of oogenesis, the egg chamber pinches off from the gerarium. Oogenesis then progresses in 13 more stages (stages 2–14) as the egg chamber is displaced towards the posterior of the ovariole. In stage 9, the majority of follicle cells start to migrate posteriorly to form a columnar epithelium over the oocyte. The remaining follicle cells cover the nurse cells and become extremely flattened (squamous). The oocyte grows steadily throughout oogenesis until stage 10, when it occupies approximately half of the egg chamber. In stage 11, the remaining nurse cell contents are rapidly dumped into the oocyte. In stages 12–14 the follicle cells secrete the eggshell, the nurse cells execute a cell death program, and a mature egg is formed.

Identification of New X-Chromosomal Loci Required for Oogenesis

To identify genes required for oogenesis, we screened for ethyl methane sulfonate (EMS) mutations on the X chromosome which lead to female infertility (Fig. 2). We identified 186 lines which we then placed into three categories according to egg morphology. Of the 186 lines, 82 produced wild type eggs that failed to hatch and therefore represent maternal effect lethal mutations or mutations that prevent fertilization. Sixty-one lines produced eggs that appeared collapsed, likely reflecting defects in chorion production or in other late stages of oogenesis. Forty-three lines produced few or no eggs or produced eggs with aberrant

morphology. Four of these lines failed to lay eggs but contained normal-looking eggs in their ovary, suggesting defects in oviposition. We focussed our studies on the remaining 39 female sterile lines.

The ovarian phenotypes of the 39 female sterile lines were determined by examining fixed ovaries which were labeled for DNA and actin. This analysis allowed us to further classify these mutants according to the stage of arrest in oogenesis. Mutants were mapped by meiotic recombination mapping, and then by complementation tests against candidate deficiencies. Alleles that mapped to the same region of the X

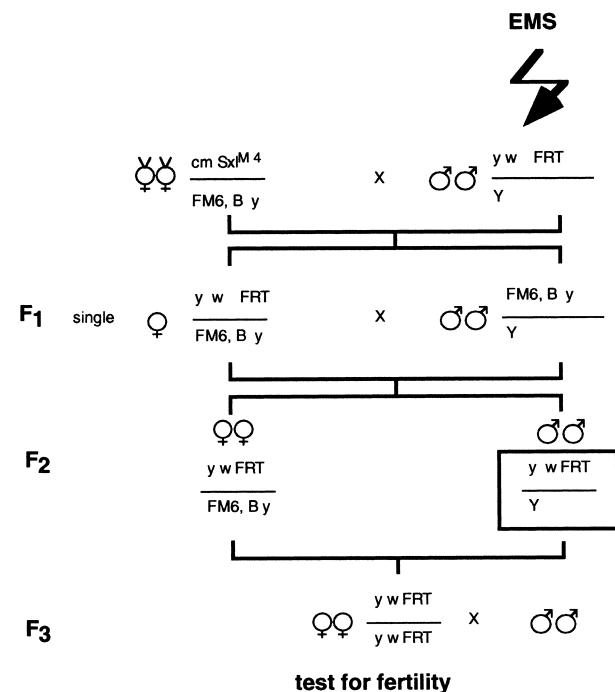

Figure 2 Crossing scheme used to isolate X chromosome female sterile lines. Males of the genotype *yw118FRT19A* (Bloomington stock B1744) were mutagenized, and F3 female progeny were tested for fertility. *SxlM4* is a male lethal allele of *Sxl* and was used to eliminate unwanted males from the first cross.

chromosome were tested inter se for complementation and to known mutants in the region. This analysis allowed us to place the 39 female sterile mutants into 30 complementation groups (Table 1).

Genes Required for Patterning of the Germarium

We have identified 12 lines representing nine complementation groups, which show mutant phenotypes in the earliest stages of oogenesis, in the germarium. Of these, four loci represent novel genes (Table 1). In *fs(1)124* mutant females, germaria are severely atrophied and only one or two egg chambers are present in an ovariole. To examine the fate of cells in these mutant ovaries, we immunostained mutant ovaries with an antibody to the fusome component adducin-like (Zaccai and Lipshitz 1996). The fusome is a membranous organelle enriched in membrane skeleton proteins, and it marks the dividing cells. In normal development, the fusome appears as a sphere (spectrosome) in stem cells and cystoblasts, whereas in dividing cystocytes it adopts a branched structure linking all of the cells of the cyst (Lin et al. 1994). In *fs(1)124* homozygous mutants, the germaria and these budded egg chambers are full of spectrosome-containing cells or small cysts of up to four cells (Fig. 3A), indicating that development arrests very early. Rarely, an egg chamber with a differentiated oocyte and multiple nurse cells is produced. This phenotype is reminiscent of the phenotypes of tumorous ovary mutants such as *otu* and *bam*, genes involved in the control of stem cell divisions or cystocyte differentiation (King and Storto 1988; McKearin and Spradling 1990), and therefore defines a new member of this class of female sterile mutations.

Females from the line *fs(1)259* produce egg chambers with variable numbers of germ cells per egg chamber, including small cysts with less than 16 cells (Fig. 3B) and large cysts with greater than 16 cells (Fig. 3C). These defects could be due to a failure to correctly pinch off 16 cell cysts from the germarium or they could reflect a failure in the cystocyte division program that generates the 16-cell cyst. The cysts with more than 16 cells have multiple oocytes (arrows in Fig. 3C), and none of these oocytes is attached to more than four ring canals, indicating that no more than the normal four cystocyte divisions took place. This suggests that these cysts are composed of multiple cysts that have been improperly packaged together. A packaging defect could also explain the existence of less than 16 cells in a cyst if somehow wild type cysts with 15 nurse cells plus an oocyte were broken up as they exited the germarium. If so, we would predict that a significant number of cysts with fewer than 16 cells would not have an oocyte. Instead, we find that almost all of the cysts with fewer than 16 cells include a single diploid oocyte nucleus (arrow in Fig. 3B), suggesting that these

cysts are not simply the result of the breaking apart of 16-cell cysts. Rather they most likely arise from a failure to complete the normal four rounds of cystocyte divisions in region 1 of the germarium. Therefore, there is evidence that *fs(1)259* mutants affect both cystocyte divisions and cyst encapsulation in the germarium.

The *fs(1)217* homozygous mutants display an age-dependent deficit in follicle cell numbers. Young females (less than three days old) produce egg chambers with a reduced number of follicle cells (compare Fig. 3D and Fig. 3E). This phenotype becomes worse with age, and older females (greater than three days old) frequently contain large fused egg chambers which appear to contain multiple 16-cell cysts and which contain few follicle cells (Fig. 3F). These fused egg chambers could be a result of there being an insufficient number of follicle cells to encapsulate egg chambers as they bud from the germarium. The phenotype of *fs(1)217* may suggest a role in follicle cell division or maintenance. A signal transduction pathway involving the *hedgehog* gene has been implicated in regulating follicle cell proliferation (Forbes et al. 1996a, 1996b), and it will be interesting to see if *fs(1)217* is involved in this pathway.

We have also identified new alleles of previously identified genes that pattern the germarium, including three new alleles of *ovarian tumor (otu)*, one allele of *sans fille (snf)*, and an allele of *Sxl* (Table 1). In addition, we identified a new allele of *fs(1)Yb*, *fs(1)Yb⁷²*, and our analysis of this mutant has provided new insights into the function of this gene. *fs(1)Yb* is required for germline encapsulation by follicle cells (Johnson et al. 1995; Fig. 4A) and for germline stem cell maintenance (King and Lin 1999). In addition to confirming these requirements, our analysis of *fs(1)Yb⁷²* suggests a new requirement in regulating cystoblast differentiation. Wild type ovaries contain two or three stem cells and approximately the same number of cystoblasts at the anterior tip of the germarium. These cells can be identified by their high level of *Sxl* expression (Fig. 4B; Bopp et al. 1993). In *fs(1)Yb⁷²/fs(1)Yb⁷²*, the number of these cells is increased and they often take up the entire anterior half of the germarium (Fig. 4C). The pattern of *Sxl* expression suggests that *fs(1)Yb⁷²* mutant stem cells or cystoblasts overproliferate in these germaria. To further ascertain the identity of these cells we examined fusome organization. In normal development the fusome appears as a sphere (spectrosome) in stem cells and cystoblasts, whereas in dividing cystocytes it adopts a branched structure linking all of the cells of the cyst (Lin et al. 1994; Fig. 4D). In *fs(1)Yb⁷²/fs(1)Yb⁷²*, the number of spectrosome-containing cells is greater than in wild type (Fig. 4E), and significantly, this number increases with the age of the female (Fig. 4F), a phenotype not observed in existing *fs(1)Yb* alleles

Table 1. Summary of Female Sterile Mutants

Genes required for patterning in the germarium			
Locus	Map position [¶]	Alleles	Notes
<i>brainiac (brn)</i>	4B2	<i>brn</i> ¹⁹⁸ <i>brn</i> ²²⁸	Both alleles are hemizygous lethal, paternally rescued maternal effect lethal over <i>brn</i> ^{fs107} . <i>brn</i> ²²⁸ / <i>brn</i> ²²⁸ is a temperature sensitive lethal. See text
<i>fs(1)Yb</i>	3B1	<i>fs(Yb)</i> ⁷² <i>otu</i> ⁵⁵	
<i>ovarian tumor (otu)</i>	7E9	<i>otu</i> ⁶⁷ <i>otu</i> ¹³⁹	<i>otu</i> ⁵⁵ and <i>otu</i> ⁹⁹ produce ovarian tumors (ONC class; Lindsley and Zimm 1992), <i>otu</i> ⁶⁷ produces later phenotypes typical of the DIF class.
<i>sans filles (snf)</i>	4F2	<i>snf</i> ¹⁴⁸	Tumorous germarium
<i>sex lethal (Sxl)</i>	6F5	<i>Sxl</i> ¹⁷⁹	Female lethal in hemizygotes. Homozygotes have tumorous ovaries. Associated with semi-lethality. 5% supernumerary nurse cells (5 ring canals on oocyte).
<i>fs(1)100</i>	lethal		
<i>fs(1)124</i>	9D1–2		See text
<i>fs(1)217</i>	26cM ± 2.5		See text
<i>fs(1)259</i>	14B1–16A7		See text
Genes required in mid-oogenesis			
Locus	Map position [¶]	Alleles	Notes
<i>dunce (dnc)</i>	3D2	<i>dnc</i> ^{221b} <i>dnc</i> ²²⁵	See text
<i>fs(1)K10</i>	2F1	<i>fs(1)K10</i> ⁴⁷ <i>fs(1)K10</i> ¹³⁰	
<i>singed</i>	7D2	<i>sn</i> ⁷⁷ <i>sn</i> ¹⁸⁴	
<i>fs(1)3</i>	5C5–5D1?		Weak phenotype over deficiency, see text*
<i>fs(1)140</i>	43cM ± 2.5		See text
<i>fs(1)186</i>	14C–15A6		
<i>fs(1)234</i>	5A8–5C2		See text
Mutations resulting in cell death or degeneration			
Locus	Map position [¶]	Alleles	Notes
<i>fs(1)56</i>	lethal		Variable germ-line degeneration after stage 9. Few eggs, some short or fused dorsal appendages.
<i>fs(1)60</i>	0–2cM ± 1.4		Variable germ-line degeneration after stage 10. No eggs laid. Degeneration in stage 9 or 10, sometimes earlier (stage 6).
<i>fs(1)127</i>	1cM ± 1		Oocyte growth retarded after stage 9, nurse cell nuclei also small. Some tumorous cysts
<i>fs(1)137a</i>	lethal		Associated with semi-lethality. Degeneration of germ-line cells usually at stage 9 but at variable stages starting in the germarium.
<i>fs(1)162</i>	9cM ± 2.7		Variable degeneration after stage 9, majority normal to stage 14. No eggs laid.
<i>fs(1)164</i>	30cM ± 3.4		See text
<i>fs(1)192</i>	24cM ± 1.6		Variable degeneration after stage 10. Rare cases of 8– or (approx.) 32– cell cysts. Most appear normal to stage 14. Females lay rare collapsed egg remnants.
<i>fs(1)221a</i>	15–16cM ± 2.4		See text
<i>fs(1)242</i>	lethal		Variable degeneration after stage 9. Females lay eggs with fused or reduced dorsal appendages.
<i>fs(1)250</i>	21cM ± 1		Degenerate after stage 12. Females lay small number of collapsed egg remnants.
<i>fs(1)260</i>	*		Degeneration in stage 10 or later. Rare failed or retarded border cell migration. Rare supernumerary nurse cells (<5%).
<i>fs(1)261EL</i>	lethal		Degeneration after stage 8. Associated with semi-lethality.
Genes required for egg shell formation			
Locus	Map position [¶]	Alleles	Notes
<i>dec-1</i>	7C6	<i>dec-1</i> ^{H12} <i>dec-1</i> ^{H13} <i>dec-1</i> ^{H15}	All alleles result in few or no eggs laid
<i>fs(1)38</i>	25cM ± 2.3	<i>fs(1)38</i> <i>fs(1)161</i>	Few eggs, defective chorion

[¶] Cytological map intervals denote limits of deficiencies that uncover the mutation; “lethal” indicates the presence of a lethal mutation on the chromosome (in the *fs* locus or outside of it) that prevents recombination mapping.

*Mapping revealed a contamination problem.

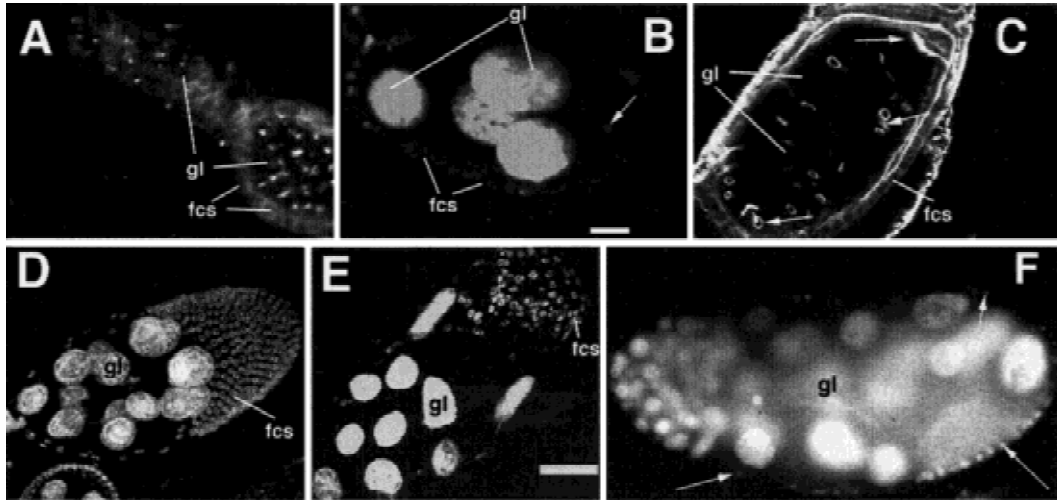

Figure 3 New genes required for patterning of the germarium. gl, germline; fcs, follicle cells. (A) Adducin-like localization in *fs(1)124/fs(1)124* mutant germarium reveals spectrosome-containing cells and small cysts with branched fusomes. (B) Nuclear staining of an *fs(1)259/fs(1)259* egg chamber containing four polyploid nurse cells and one oocyte nucleus (arrow). Scale bar = 10 μ m. (C) Actin staining of an *fs(1)259/fs(1)259* egg chamber containing multiple nurse cell/oocyte cysts. Arrows point to oocytes. (D) Nuclear staining of a late stage 9 wild type egg chamber. (E) Nuclear staining of a late stage 9 *fs(1)217/fs(1)217* egg chamber from a 2-d-old female, revealing a reduced number of follicle cells. Scale bar = 50 μ m. (F) Large fused egg chamber from a 6-d-old *fs(1)217/fs(1)217* female. Only a small number of follicle cells surround this egg chamber. Arrows point to follicle cell nuclei.

(King and Lin 1999). Clones of *fs(1)Yb⁷²* produce wild type egg chambers and reveal no defects in fusome formation, indicating a somatic cell requirement for *fs(1)Yb⁷²* as has been reported for other *fs(1)Yb* alleles (data not shown; King and Lin 1999).

The germline cells of *fs(1)Yb⁷²/fs(1)Yb⁷²* females do not generate normal cysts since very few 16-cell cysts are formed in these mutants (data not shown) and germaria become cleared of dividing cystocyte clusters (with branched fusomes) within 24 h (Fig. 4E). This phenotype can be explained in either of two ways. One possibility is that in *fs(1)Yb⁷²* mutants, stem cells divide symmetrically to produce two daughter stem cells. This appears to conflict with the finding of King and Lin (1999) and our own data (not shown) that *fs(1)Yb* mutant stem cells divide symmetrically to produce two daughter cystoblast cells. The second possibility is that stem cell divisions are normal but there is a defect at the level of cystoblast division. Normally the first mitotic division of the cystoblast involves an incomplete cytokinesis giving rise to two fusome-linked daughter cystocytes. The increased number of Sxl-positive and spectrosome-containing cells in *fs(1)Yb⁷²* could arise if the cystoblasts undergo complete divisions. Both daughter cells may then continue to divide as cystoblasts, again undergoing complete cytokinesis, leaving the germ cells locked in the dividing cystoblast stage. This possible requirement for *fs(1)Yb* in the differentiation of a cystocyte from a cystoblast could mechanistically relate to the earlier requirement

in the differentiation of a cystoblast from a stem cell described by King and Lin (1999). Two findings argue that the *fs(1)Yb⁷²* mutant phenotype is not caused by a second site mutation. First, recombination mapping only revealed one female sterile locus on this chromosome. Second, germline clones of *fs(1)Yb⁷²* produce wild type eggs, indicating that the chromosome is free of germline-dependent female sterile mutations.

We also identified two new alleles of *brainiac* (*brn*; Goode et al. 1992), i.e., *brn¹⁹⁸* and *brn²²⁸*. Two other alleles of *brn* have been previously described. *brn^{1.6P6}* is homozygous lethal, and homozygous germline clones result in a female sterile phenotype in which follicle cells fail to properly surround and segregate germline cysts, resulting in the production of fused egg chambers. *brnfs¹⁰⁷* is homozygous viable and a maternal effect lethal. The maternal effect lethality is paternally rescuable (Goode et al. 1992). Ovaries from homozygous *brn¹⁹⁸* females consist of large germaria consisting of multiple germarial cysts. These ovarioles apparently lack stalk cells, the specialized follicle cells which normally separate cysts from each other (Fig. 3G). This phenotype is similar to that seen in *brn^{1.6P6}* homozygous germline clones (Goode et al. 1992, 1996). The primary defect in *brn^{1.6P6}* is thought to be due to a failure of follicle cells to extend processes towards the germline cyst during cyst encapsulation (Goode et al. 1996). *brn²²⁸/brn²²⁸* displays a more severe ovarian phenotype: ovaries are much smaller than in *brn^{1.6P6}* germline clones or *brn¹⁹⁸/brn¹⁹⁸*,

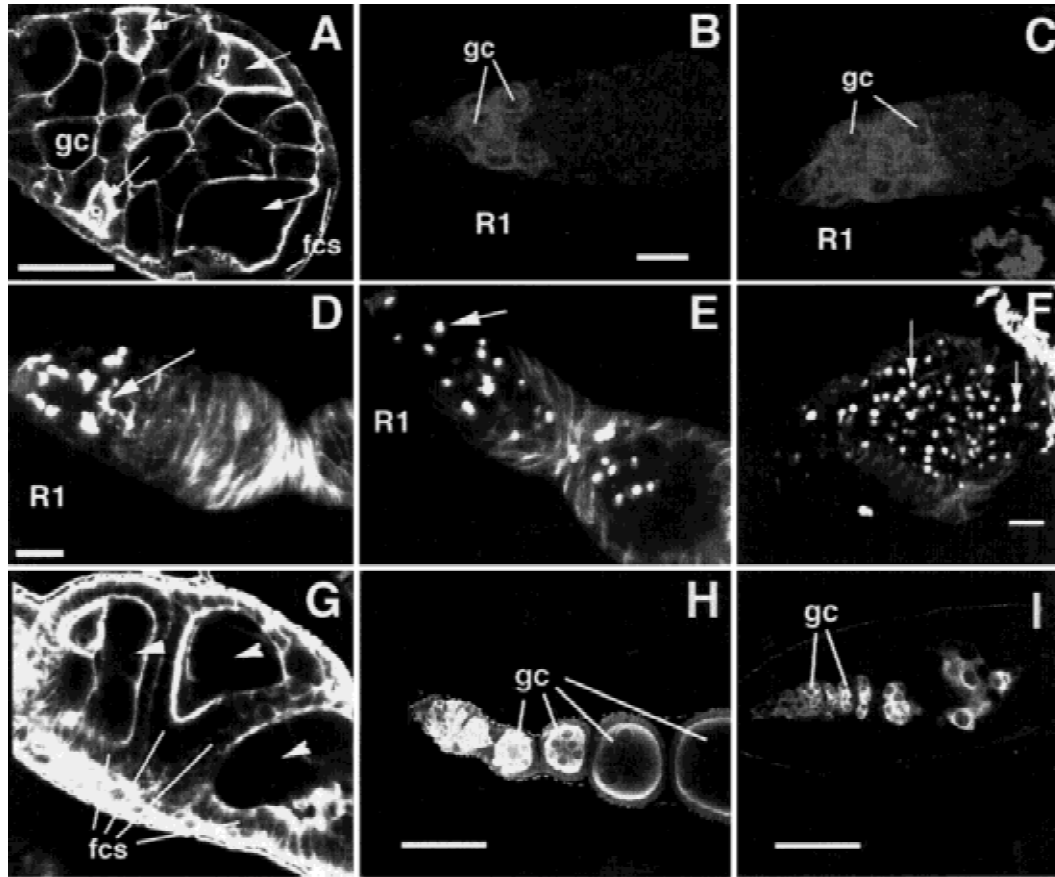

Figure 4 Requirements for *fs(1)Yb* (A-F) and *brn* (G-I) in patterning of the germarium. fcs, somatic follicle cells; gc, germ cells; R1: germarial region 1. (A) Actin staining of *fs(1)Yb⁷²/fs(1)Yb⁷²* mutant germarium revealing multiple cysts within a single egg chamber. Arrows point to oocytes. Scale bar = 50 μ m. (B,C) *Sxl* localization in 1-d-old wild type (B) and *fs(1)Yb⁷²/fs(1)Yb⁷²* (C) mutant germaria. Scale bar = 10 μ m. (D,E,F) Adducin-like localization in 1-d-old wild type (D), 1-d-old *fs(1)Yb⁷²/fs(1)Yb⁷²* (E), and 6-d-old *fs(1)Yb⁷²/fs(1)Yb⁷²* (F) germaria. Arrow in (D) points to a branched fusome. Arrows in (E,F) point to unbranched fusomes (spectrosomes). Scale bars = 10 μ m. (G) Actin staining of a *brn¹⁹⁸/brn¹⁹⁸* mutant ovariole which lacks stalk cells, resulting in failure to separate egg chambers. Three egg chambers are labeled with arrowheads. (H) Germline staining with anti-Vasa antibody of a wild type germarium and early-stage egg chambers, revealing the continuously growing germline cells. (I) Vasa staining of a *brn²²⁸/brn²²⁸* ovariole revealing depletion of germline cells. Scale bar in (H,I) = 50 μ m.

and immunostaining for the germline marker Vasa reveals very few germline cells after region 2 of the germarium (compare Fig. 4H to Fig. 4I). Therefore *brn* function appears to be necessary for germline survival. The heteroallelic combination *brn²²⁸/brn¹⁹⁸* also displays a germline loss phenotype, though this is less severe than in *brn²²⁸* homozygotes (data not shown), suggesting that the phenotype of *brn²²⁸* mutants is due to loss of *brn* activity and is not due to a second site modifier on the *brn²²⁸* chromosome. It has been proposed that *brn* could be involved in the production of a signal from the germline that specifies follicle cell fates. Indeed, *brn* mutants show disruption of follicle cell behavior at multiple stages of development (Goode et al. 1992, 1996). The loss of germline cells in the severe *brn* mutant could be a secondary effect resulting from an even more severe disruption of follicle cell

fate. An alternative interpretation is that partial lack of *brn* activity compromises the ability of germline cells to be recognized and correctly encapsulated by follicle cells, while a more severe loss of *brn* activity leads to death of these germline cells. The two new alleles allow us to define an allelic series for *brainiac* in the ovary: *brn²²⁸* > *brn^{1.6P6}* (germline clones) = *brn¹⁹⁸* > *brn^{fs107}*. The two *brn* alleles we have identified are lethal over a deficiency for the region, and one of them, *brn²²⁸*, is a temperature-sensitive lethal when homozygous. Therefore, for the zygotic requirement the *brn* alleles can be ordered from strongest to weakest as: *brn^{1.6P6}* > *brn²²⁸* > *brn¹⁹⁸* > *brn^{fs107}*.

Genes Required for Developmental Events in Mid- to Late Oogenesis

We identified 10 mutants representing seven comple-

mentation groups which display specific defects in mid- to late oogenesis. These include two alleles each of the genes *singed*, *fs(1)K10* and *dunce* (Table 1). The other four lines in this class appear to represent novel mutants. *fs(1)186* displays a novel phenotype which may point to the existence of an oocyte-derived signal controlling follicle cell migration. In the wild type, follicle cells start to cluster over the oocyte in stage 9. In *fs(1)186*, follicle cells become asymmetrically distributed over the 16-cell cyst as early as stage 2 of oogenesis. While most follicle cells still contact the germline, some of these cells become displaced from the follicle cell monolayer (arrowheads in Fig. 5A). Later in oogenesis, follicle cells are often found in multiple layers over the oocyte (Fig. 5B). This later phenotype is similar to that seen in follicle cell clones of α -spectrin, a gene required for the integrity of the follicle cell monolayer (Lee et al. 1997). However, the earlier phenotype, the clustering of follicle cells (Fig. 5A), is not seen in

α -spectrin clones, suggesting that *fs(1)186* affects epithelial integrity in a different way. The early clustering of the mutant follicle cells occurs specifically over the oocyte (Fig. 5A), suggesting that this aberrant behavior depends on an oocyte-derived signal. Supporting this possibility, we find that the *fs(1)186* mutant phenotype is partially suppressed by mutations in *Bic-D* (Fig. 5C), a gene required for differentiation of the oocyte (Mohler and Wieschaus 1986; Suter et al. 1989). *fs(1)186* maps genetically to position 1–66 and is uncovered by a deficiency in this region (Table 1), though the mutant phenotype is milder over this deficiency than when homozygous. This could indicate that *fs(1)186* is a gain-of-function mutation, and an interesting possibility is that the *fs(1)186* mutation causes premature activation of an oocyte-dependent follicle cell migration event which normally occurs in stage 9. The stage 9 migration of follicle cells over the oocyte is normally concurrent with the differentiation of squa-

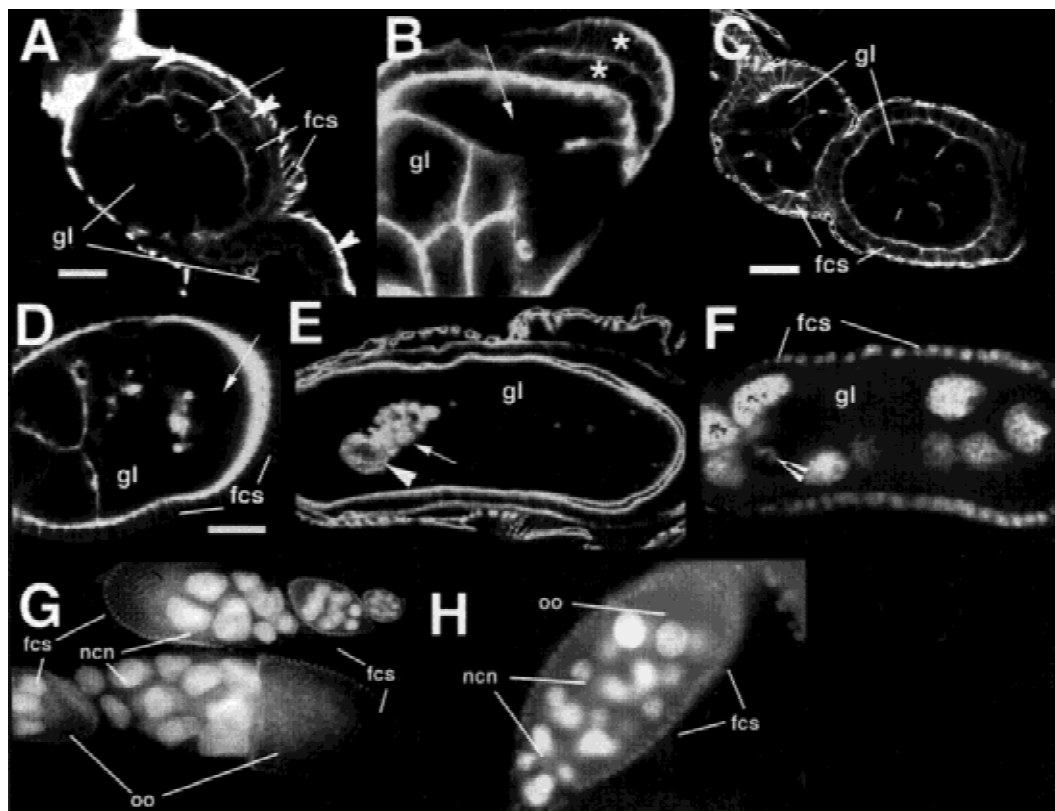

Figure 5 Genes required for mid-oogenesis. (A) *fs(1)186/fs(1)186* mutant's egg chamber labeled for actin to show abnormal aggregation of follicle cells over the oocyte. The arrowheads point out some of the follicle cells that do not contact the germline. (B) Stage 9 egg chamber from *fs(1)186/fs(1)186* in which follicle cells have formed a two-layer epithelium over the oocyte (* indicates follicle cell layers). (C) The follicle cell aggregation phenotype is partially suppressed in *fs(1)186/fs(1)186; Bic-D^{PA66}/Df(2L)TW119*. (D,E) Actin staining in a stage 5 (D) and a stage 9 (E) *fs(1)234/fs(1)234* mutant egg chamber showing the progressive loss of germline cell membranes. (F) Same egg chamber as in (E) stained for nuclei. The strong actin staining in (E) is due to aggregation of ring canals (arrow in E) and the border cells (arrowhead in E and F). Scale bars in (A,C,D) = 20 μ m. Nuclear labeling of *fs(1)225/fs(1)225* mutant ovaries reveals (G) enlarged nurse cell nuclei and (H) supernumerary nurse cells.

mous follicle cells which cover the nurse cells (see Fig. 1). We do not detect any squamous follicle cells in the early egg chambers from *fs(1)186* mutants, and therefore not all aspects of follicle cell fate change are prematurely induced in these mutants. An alternative model considers the finding that the oocyte and posterior follicle cells normally show a high mutual affinity in region 3 of the germarium, due to their co-expression of D/E-cadherin. This homophilic interaction is normally involved in positioning the oocyte (Gonzalez-Reyes and St. Johnston 1998; Godt and Tepass 1998). Other follicle cells likely also have a weak affinity for the oocyte in early oogenesis since they also express low levels of Cadherin (Gonzalez-Reyes and St. Johnston 1998; Godt and Tepass 1998). If *fs(1)186* mutants disrupt lateral adhesion between follicle cells, the weak affinity of these cells for the oocyte may cause them to cluster over the oocyte.

The *fs(1)234* homozygous or hemizygous mutants display a striking phenotype in which germline cell membranes start breaking down as early as stage 2 (Fig. 5D). By stage 9, the cysts have become transformed into a large syncytium in which only few or none of the cell membranes are left (Fig. 5E, F). A similar though less severe phenotype is seen in *armadillo* mutants (*arm*; Peifer et al. 1993) or when a dominant negative form of *cdc42* is expressed (Murphy and Montell 1996). Both of these genes have been implicated in regulating the cortical actin cytoskeleton. Mutations in *protein kinase A* (*PKA*) and *cut* also result in a breakdown of germline cell membranes; these genes have also been implicated in the regulation of the actin cytoskeleton by virtue of genetic interaction with other regulators of the actin cytoskeleton (Lane and Kalderon 1993; Jackson and Blochlinger 1997; Jackson and Berg 1999). *fs(1)234* could also belong in this pathway, though a deficiency that uncovers *fs(1)234* (see Table 1) failed to interact genetically with *cut* (Jackson and Berg 1999). *fs(1)234* is particularly interesting in that it appears to only affect membrane integrity in the germline, whereas *cdc42*, *arm*, *PKA* and *cut* all play multiple roles in oogenesis and in other tissues (Lane and Kalderon 1993; Peifer et al. 1993; Murphy and Montell 1996; Jackson and Blochlinger 1997).

Two female sterile lines, *fs(1)221b* and *fs(1)225* are allelic and display a phenotype in which nurse cell nuclei become dramatically enlarged compared to wild type (Fig. 5G; Table 2). This could be due to failure to maintain a correct chromosome configuration, leading to more diffuse staining with DNA stains, or alternatively, it could be due to the presence of more DNA due to additional endoreplication cycles. In addition, *fs(1)221b* and *fs(1)225* homozygous mutants produce rare egg chambers with 31 nurse cells + 1 oocyte instead of the normal 15 nurse cells + 1 oocyte (Fig. 5H; Table 2), suggesting a failure in mitotic control during

Table 2. Dunce Oogenesis Phenotypes

Genotype	Large nuclei	32- cell cysts	Egg retention
<i>dnc²²⁵/dnc²²⁵</i>	yes	yes	yes
<i>dnc^{221b}/dnc^{221b}</i>	yes	yes	yes
<i>dnc²²⁵/dnc^{M14}</i>	yes	yes	yes
<i>dnc^{M14}/Df(1)64i16</i>	yes	yes	yes
<i>dnc²²⁵ germ line clones</i>	yes	na	no
<i>dnc^{221b}/dnc^{M14}; rut²/+</i>	yes	yes	no

(na) Phenotype not observed but sample size too small.

the cystocyte divisions which produce the oocyte. Furthermore, *fs(1)221b* and *fs(1)225* display an egg retention phenotype (Table 2).

Cytogenetic mapping and complementation analysis revealed that these two mutations are alleles of *dunce* (*dnc*). The *dnc* gene encodes the *Drosophila* cAMP phosphodiesterase, an enzyme which degrades the second messenger cAMP. In most cell types, cAMP acts upstream of the serine-threonine protein kinase PKA to regulate a number of signaling processes, including growth, cell cycle control, and chromatin condensation (Vossler et al. 1997; Depoortere et al. 1998; Collas et al. 1999). Previous studies of oogenesis in *dnc* mutants have revealed an egg retention phenotype and maternal effect lethality in germline clones (Bellen et al. 1987), but they did not describe any defects in nurse cell nuclear morphology or germline division. We therefore reexamined existing *dnc* alleles, and found that *dncM14* also displays the nuclear morphology and extra mitosis phenotypes (Table 2).

To find out whether the nurse cell nuclear morphology phenotype is caused by lack of *dnc* in the somatic tissue or in the germline, we made germline clones of *dnc225*. These mutant clones display the nurse cell nuclear morphology defect (Table 2), indicating that *dnc* is required in the germline for its growth control. Surprisingly, these *dnc* germline clones can produce viable progeny despite having the aberrant nuclear morphology phenotype. This altered nuclear morphology therefore does not prevent progression through oogenesis or later embryonic viability. This is in contrast to the *dnc* egg retention phenotype which reflects a somatic requirement for *dnc* (Bellen et al. 1987). The *rutabaga* gene encodes an adenylate cyclase and has been previously found to act as a suppressor of both the egg laying defects and the maternal effect lethality of embryos from *dnc* females (Bellen et al. 1987). We wanted to find out whether *rut* also suppresses the oogenesis phenotypes of *dnc*. While *rut²¹* partially rescues the egg laying and embryonic lethality of *dnc²²¹/dnc^{M14}*, it fails to rescue the nuclear morphology or cystocyte division defects (Table 2).

We identified five lines that have defects in intracellular transport in late oogenesis. The mutants arrest in late oogenesis and fail to transport nurse cell contents into the oocyte. One of these lines is a DIF class allele of *otu* (Table 1). Two others represent new alleles of *singed* (*sn*), a gene required for proper bundling of actin cables during the rapid phase of nurse cell-to-oocyte transport which occurs in stage 11 of oogenesis (Cant et al. 1994). In *sn*⁷⁷ and *sn*¹⁸⁴ mutants, as in other alleles of *sn*, nurse cell nuclei are not anchored within the nurse cells and become trapped in ring canals during the dumping process, apparently thus blocking transport (Cant et al. 1994). *sn* encodes an actin binding protein, and other dumpless mutants have been found to encode polypeptides which regulate the actin cytoskeleton (Cooley and Theurkauf 1994). The other two dumpless mutants identified in our screen, *fs(1)140* (Fig. 6A) and *fs(1)3* (Fig. 6B) appear to define new loci. *fs(1)140* homozygous mutants fail to produce nurse cell actin bundles (Fig. 6C), suggesting that this gene could encode a factor that is involved in actin bundle assembly. In *fs(1)3/fs(1)3*, radial actin bundles form normally (Fig. 6D) but dumping

does not occur (Fig. 6B), suggesting the possibility that this mutant is defective in generating the actual force for dumping. The *fs(1)3* mutation has only a mild phenotype in trans to deficiencies in the 5C5–5D1 region. Recombination mapping suggests that the phenotype is a result of a combination of the *fs(1)3* mutation in the 5C5–5D1 region (1–17.0) and an enhancer mutation in the proximal part of the X chromosome (data not shown).

Mutations Resulting in Apoptosis or Degeneration

Twelve mutant lines result in ovary degeneration or apoptosis, and complementation results indicate that they all represent different loci. It is possible that many of these mutants represent germline-specific alleles of genes required throughout development for cell viability. Mutants in *fs(1)164* appear normal up until the onset of vitellogenesis in stage 8. Stage 8 and later nurse cell nuclei become pycnotic, and egg chambers degenerate (Fig. 6E). In *fs(1)221a*, nurse cell nuclei become pycnotic slightly later, by stage 10. In these mutants, follicle cells migrate anteriorly over the degenerating nurse cells instead of centripetally to separate the nurse cells from the oocyte. A similar mis-migration occurs in *fs(1)234* mutants which lack nurse cell membranes. In addition to a failure in centripetal cell migration, *fs(1)221a* mutants often display failed or retarded border cell migration (Fig. 6F). The border cells normally segregate from the follicle cell epithelium at the anterior of the oocyte beginning in stage 9 and migrate between nurse cells towards the oocyte. It is possible that the defects in centripetal cell migration and in border cell migration in *fs(1)221a* are due to the absence of correct signaling from the nurse cells. Both border cell migration and centripetal cell migration depend on E-cadherin-based interactions between the migrating cells and nurse cells (Niewiadomska et al. 1999).

We also identified five mutants representing two complementation groups in which females lay a small number of degenerating eggs which appear to have defects in chorion formation. We found that one of these complementation groups corresponds to *dec-1* (Table 1).

Conclusion

We have identified 186 new maternal effect mutations. We were particularly interested in mutants that affect oogenesis, and therefore we focussed on those that fail to produce morphologically normal eggs. Thirty-nine mutants were found in this category. Using this criterion for classifying oogenesis mutants, the screen of Gans et al. (1975) yielded 16 mutants affecting oogenesis from a total of 95 sterile lines, while the screen of Mohler (1977) yielded 55 oogenesis mutants from a total of 324 sterile lines (Mohler 1977; Mohler and Car-

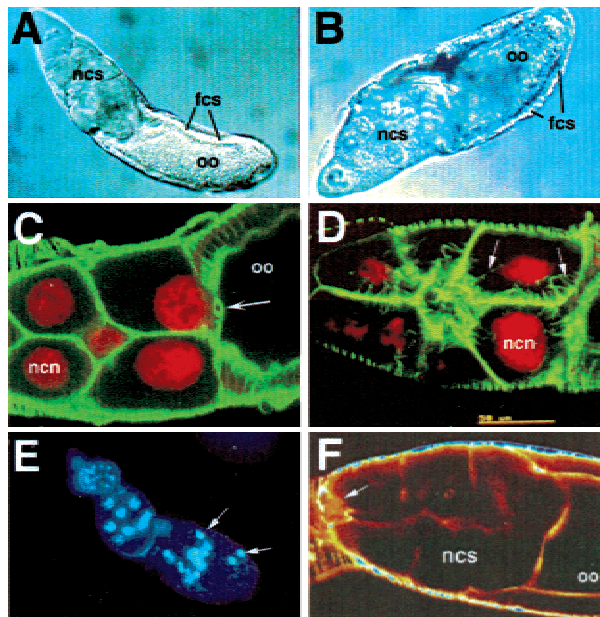

Figure 6 (A–D) Defects in late transport of nurse cell contents in mutants for *fs(1)140* and *fs(1)3*. oo, oocyte; fcs, follicle cells; ncs, nurse cells; ncn, nurse cell nucleus. (A,B) Nomarski views of (A) *fs(1)140* and (B) *fs(1)3* egg chambers in which nurse cell dumping has failed. (C,D) Double labeling of nuclei (red) and actin (green) in (C) *fs(1)140/fs(1)140* and (D) *fs(1)3/fs(1)3*. In *fs(1)140/fs(1)140*, actin cables fail to form and the nurse cell nuclei appear to become caught in the ring canals (arrow) during dumping. In *fs(1)3/fs(1)3*, actin cables form normally (arrows point to actin cables). (E) Nuclear staining of *fs(1)164/fs(1)164* reveals pycnotic nuclei (arrows) in stage 8 of oogenesis. (F) Actin staining of *fs(1)221a/fs(1)221a* reveals failed border cell migration (arrow points to border cells).

roll 1984). As in these previous screens, the majority of the lines that we have isolated are apparently single alleles, and most of these are predicted to represent novel genes (Perrimon et al. 1986). Our preliminary analysis of these female sterile mutants suggests that this will be a valuable collection for the study of developmental processes in the *Drosophila* ovary.

METHODS

Generation of Female Sterile Mutations

All stocks were obtained from the Bloomington stock center unless otherwise noted. Male *Drosophila* of the genotype ywFRT19A (Bloomington stock 1744) were EMS mutagenized by standard methods (Lewis and Bacher 1968). Approximately 1700 F3 females (see Fig. 2) were tested for fertility by allowing them to lay eggs in chambers for several days. FRT sites are included on the mutagenized chromosomes to facilitate clonal analysis (Chou and Perrimon 1992).

Mapping of Female Sterile Mutants

Female sterile mutants were mapped by recombination mapping relative to the markers y (0.0 cM), a mini-white-containing *P*-element insertion at 7D1-2 (21.0 cM) and B (57.0 cM). From 100 to 200 progeny were scored in each recombination experiment. Deficiencies from the Bloomington stock center deficiency kit were used to cytogenetically map mutants.

Antibody Stainings

Antibody stainings were performed as described (Suter and Steward 1991). Monoclonal anti-adducin-like antibody 2C1 (Zaccari and Lipshitz, 1996) was obtained from Howard Lipshitz and used at 1/40. Affinity purified rabbit anti-Vasa antibody was obtained from Akira Nakamura and Paul Lasko (Styhler et al. 1998) and used at 1/1,000. Monoclonal anti-*Sxl* 18 (Bopp et al. 1993) was obtained from Daniel Bopp and Paul Schedl and used at 1/10. DNA was labelled using Oligreen (Molecular Probes) at 1/500 of a 1mg/ml stock after an initial RNase treatment, or by using Hoechst 33342 (Molecular Probes) at 1µg/mL. Texas-Red Phalloidin (Molecular Probes) was used at 1/200 of a 200U/mL stock. Secondary antibodies, Oregon green anti-mouse and Texas Red-X anti-rabbit, were obtained from Molecular Probes and used at 1/1,000.

ACKNOWLEDGMENTS

We thank Trudi Schüpbach for critical reading of the manuscript. This work was supported by the National Science and Engineering Research Council of Canada, by the National Cancer Institute of Canada with funds from the Canadian Cancer Society, and by an MRC genomics grant. B.S. was a Research Scientist of the National Cancer Institute of Canada supported by funds from the Canadian Cancer Society.

The publication costs of this article were defrayed in part by payment of page charges. This article must therefore be hereby marked "advertisement" in accordance with 18 USC section 1734 solely to indicate this fact.

REFERENCES

Adams, M.D. 2000. The genome sequence of *Drosophila melanogaster*. *Science* **287**: 2185–2195.

Adams, M., Celniker, S., Holt, R., Evans, C., Gocayne, J., Amanatides,

P., Scherer, S., Li, P., Hoskins, R., Galle, R., et al. 2000. The genome sequence of *Drosophila melanogaster*. *Science* **287**: 2185–2195.

Bellen, H. J., Gregory, B. K., Olsson, C. L., and Kiger Jr., J. A. 1987. Two *Drosophila* learning mutants, *dunce* and *rutabaga*, provide evidence of a maternal role for cAMP on embryogenesis. *Dev. Biol.* **121**: 432–444.

Bopp, D., Horabin, J. I., Lersch, R. A., Cline, T. W., and Schedl, P. 1993. Expression of the Sex-lethal gene is controlled at multiple levels during *Drosophila* oogenesis. *Development* **118**: 797–812.

Cant, K., Knowles, B. A., Mooseker, M. S., and Cooley, L. 1994. *Drosophila singed*, a fascin homolog, is required for actin bundle formation during oogenesis and bristle extension. *J. Cell Biol.* **125**: 369–380.

Chou, T. B. and Perrimon, N. 1992. Use of a yeast site-specific recombinase to produce female germline chimeras in *Drosophila*. *Genetics* **131**: 643–653.

Collas, P., Le Guellec, K., and Tasken, K. 1999. The A-kinase-anchoring protein AKAP95 is a multivalent protein with a key role in chromatin condensation at mitosis. *J. Cell Biol.* **147**: 1167–1180.

Cooley, L. and Theurkauf, W. E. 1994. Cytoskeletal functions during *Drosophila* oogenesis. *Science* **266**: 590–596.

Depoortere, F., Van Keymeulen, A., Lukas, J., Costagliola, S., Bartkova, J., Dumont, J. E., Bartek, J., Roger, P. P., and Dremier, S. 1998. A requirement for cyclin D3-cyclin-dependent kinase (cdk)-4 assembly in the cyclic adenosine monophosphate-dependent proliferation of thyrocytes. *J. Cell Biol.* **140**: 1427–1439.

Forbes, A.J., Lin, H., Ingham, P.W., and Spradling, A.C. 1996a. *hedgehog* is required for the proliferation and specification of ovarian somatic cells prior to egg chamber formation in *Drosophila*. *Development* **122**: 1125–1135.

Forbes, A.J., Spradling, A.C., Ingham, P.W., and Lin, H. 1996b. The role of segment polarity genes during early oogenesis in *Drosophila*. *Development* **122**: 3283–3294.

Gans, M., Audit, C., and Masson, M. 1975. Isolation and characterization of sex-linked female-sterile mutants in *Drosophila melanogaster*. *Genetics* **81**: 683–704.

Godt, D. and Tepass, U. 1998. *Drosophila* oocyte localization is mediated by differential cadherin-based adhesion. *Nature* **395**: 387–391.

Gonzalez-Reyes, A. and St. Johnston, D. 1998. The *Drosophila* AP axis is polarised by the cadherin-mediated positioning of the oocyte. *Development* **125**: 3635–3644.

Goode, S., Melnick, M., Chou, T.B., and Perrimon, N. 1996. The neurogenic genes *egghead* and *brainiac* define a novel signaling pathway essential for epithelial morphogenesis during *Drosophila* oogenesis. *Development* **122**: 3863–3879.

Goode, S., Wright, D., and Mahowald, A. P. 1992. The neurogenic locus *brainiac* cooperates with the *Drosophila* EGF receptor to establish the ovarian follicle and to determine its dorsal-ventral polarity. *Development* **116**: 177–192.

Jackson, S.M. and Berg, C.A. 1999. Soma-to-germline interactions during *Drosophila* oogenesis are influenced by dose-sensitive interactions between cut and the genes *cappuccino*, *ovarian tumor* and *agnostic*. *Genetics* **153**: 289–303.

Jackson, S.M. and Blochliger, K. 1997. *cut* interacts with *Notch* and *protein kinase A* to regulate egg chamber formation and to maintain germline cyst integrity during *Drosophila* oogenesis. *Development* **124**: 3663–3672.

Johnson, E., Wayne, S., and Nagoshi, R. 1995. *fs(1)Yb* is required for ovary follicle cell differentiation in *Drosophila melanogaster* and has genetic interactions with the Notch group of neurogenic genes. *Genetics* **140**: 207–217.

King, F. J. and Lin, H. 1999. Somatic signaling mediated by *fs(1)Yb* is essential for germline stem cell maintenance during *Drosophila* oogenesis. *Development* **126**: 1833–1844.

King, R. C. and Storto, P. D. 1988. The role of the *otu* gene in *Drosophila* oogenesis. *BioEssays* **8**: 18–24.

Lane, M.E. and Kalderon, D. 1993. Genetic investigation of

- cAMP-dependent protein kinase function in *Drosophila* development. *Genes & Dev.* **7**: 1229–43.
- Lee, J. K., Brandin, E., Branton, D., and Goldstein, L.S.B. 1997. α -Spectrin is required for ovarian follicle cell monolayer integrity in *Drosophila melanogaster*. *Development* **124**: 353–362.
- Lewis, E. and Bacher, F. 1968. Method of feeding ethyl methane sulfonate (EMS) to *Drosophila* males. *Dros. Inform. Serv.* **43**: 193.
- Lin, H., Yue, L., and Spradling, A. C. 1994. The *Drosophila* fusome, a germline-specific organelle, contains membrane skeletal proteins and functions in cyst formation. *Development* **120**: 947–956.
- Lindsley, D. L. and Zimm, G. G. 1992. The genome of *Drosophila melanogaster*. Academic Press, Inc., San Diego.
- McKearin, D., and Spradling, A. C. 1990. *bag-of-marbles*: a *Drosophila* gene required to initiate both male and female gametogenesis. *Genes & Dev* **4**: 2242–2251
- Mohler, J.D. 1977. Developmental genetics of the *Drosophila* egg. I. Identification of 59 sex-linked cistrons with maternal effects on embryonic development. *Genetics* **85**: 259–272.
- Mohler, D. and Carroll, A. 1984. Report of new mutants. *D.I.S.* **60**: 236–241.
- Mohler, J. and Wieschaus, E. F. 1986. Dominant maternal-effect mutations of *Drosophila melanogaster* causing the production of double-abdomen embryos. *Genetics* **112**: 803–822
- Murphy, A. M. and Montell, D. J. 1996. Cell type-specific roles for Cdc42, Rac, and RhoL in *Drosophila* oogenesis. *J. Cell Biol.* **133**: 617–630.
- Niewiadomska, P., Godt, D., and Tepass, U. 1999. DE-Cadherin is required for intercellular motility during *Drosophila* oogenesis. *J. Cell Biol.* **144**: 533–547.
- Peifer, M., Orsulic, S., Sweeton, D., and Wieschaus, E. 1993. A role for the *Drosophila* segment polarity gene *armadillo* in cell adhesion and cytoskeletal integrity during oogenesis. *Development* **118**: 1191–1207.
- Perrimon, N., Mohler, D., Engstrom L., and Mahowald, A.P. 1986. X-linked female-sterile loci in *Drosophila melanogaster*. *Genetics* **113**: 695–712.
- Rubin, G. M., Yandell, M.D., Wortman, J.R., Miklos, G.L.G., Nelson, C.R., Hariharan, I.K., Fortini, M.E., Li, P.W., Apweiler, R., Fleischmann et al. 2000. Comparative genomics of the eukaryotes. *Science* **287**: 2204–2215.
- Schupbach, T. and Wieschaus, E. 1991. Female sterile mutations on the second chromosome of *Drosophila melanogaster*. II. Mutations blocking oogenesis or altering egg morphology. *Genetics* **129**: 1119–1136.
- Spradling, A. C., 1993. Developmental genetics of oogenesis, pp. 1–70. in *The Development of Drosophila melanogaster*, edited by B. M. Arias, CSHL Press, Cold Spring Harbor, NY.
- Styhler, S., Nakamura, A., Swan, A., Suter, B., and Lasko, P. 1998. Vasa regulates *grk* translation and is involved in oocyte determination and germline cyst development. *Development* **125**: 1569–1578.
- Suter, B., Romberg, L. M., and Steward, R. 1989. *Bicaudal-D*, a *Drosophila* gene involved in developmental asymmetry: localized transcript accumulation in ovaries and sequence similarity to myosin heavy chain tail domains. *Genes & Dev.* **3**: 1957–1968.
- Suter, B. and Steward, R. 1991. Requirement for phosphorylation and localization of the Bicaudal-D protein in *Drosophila* oocyte differentiation. *Cell* **67**: 917–926.
- Vossler, M. R., Yao, H., York, R. D., Pan, M. G., Rim, C. S., and Stork, P. J. 1997. cAMP activates MAP kinase and Elk-1 through a B-Raf- and Rap1-dependent pathway. *Cell* **89**: 73–82.
- Zaccai, M. and Lipshitz, H.D. 1996. Differential distributions of two adducin-like protein isoforms in the *Drosophila* ovary and early embryo. *Zygote* **4**: 159–166.

Received July 18, 2000; accepted in revised form October 27, 2000.